

Finding the Exact Area Under a Curve - Classwork

Now that we have used a finite number of right, left, and mid rectangles as well as trapezoids to approximate the area under a curve, we now extend the concept to finding the exact area under the curve by looking at n rectangles and calculating the limit of the sum of the areas of those rectangles as n approaches infinity.

In the method shown below, we will assume right rectangles. Left rectangles are possible as well but since either method will give the same answer, we will just settle on one method. This and the next page will be set up so that the general method and description will be on the left side of the page, and an example (specific problem) will be on the right side.

General Problem: Find the exact area between a curve $y = f(x)$, the x -axis, and $x = a$ and $x = b$. We assume the graph will be above the x -axis.

Specific Problem: Find the exact area between the curve $f(x) = x^2 + 1$, the x -axis, and $x = 1$ and $x = 3$

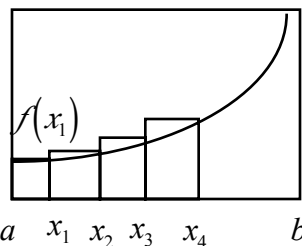

- Make a simple sketch of the function

- Determine Δx = the base of each rectangle

$$\Delta x = \frac{b-a}{n} \text{ where } n = \text{the number of rectangles}$$

$$\Delta x = \frac{3-1}{n} = \frac{2}{n}$$

- Find the x -coordinates of the right leg of each rectangle, $x_1, x_2, x_3, \dots, x_i$

$$x_i = a + i\Delta x$$

$$x_i = a + i\frac{2}{n} = 1 + \frac{2i}{n}$$

- Find the heights of the right leg of each rectangle

$$f(x_1), f(x_2), f(x_3), \dots, f(x_i)$$

The algebra can be messy.

$$\begin{aligned} f(x_i) &= f\left(1 + \frac{2i}{n}\right) \\ &= \left(1 + \frac{2i}{n}\right)^2 + 1 \\ &= 1 + \frac{4i}{n} + \frac{4i^2}{n^2} + 1 \\ &= 2 + \frac{4i}{n} + \frac{4i^2}{n^2} \end{aligned}$$

- Now we need the area of each rectangle

$$A_1, A_2, A_3, \dots, A_i$$

A_i = base of rectangle _{i} • height of rectangle _{i}

The power of i is always 1 less than the power of n

$$A_i = \left(\frac{2}{n}\right) \left(2 + \frac{4i}{n} + \frac{4i^2}{n^2}\right)$$

$$= \frac{4}{n} + \frac{8i}{n^2} + \frac{8i^2}{n^3}$$

- Now we need to sum up all the areas

$$A = \sum_{i=1}^n A_i$$

$$A = \sum_{i=1}^n \left(\frac{4}{n} + \frac{8i}{n^2} + \frac{8i^2}{n^3} \right)$$

- Distribute the \sum and factor out the constant and n 's.

Everything to the right of the \sum should be 1 or i 's

$$A = \sum_{i=1}^n \frac{4}{n} + \sum_{i=1}^n \frac{8i}{n^2} + \sum_{i=1}^n \frac{8i^2}{n^3}$$

$$A = \frac{4}{n} \sum_{i=1}^n 1 + \frac{8}{n^2} \sum_{i=1}^n i + \frac{8}{n^3} \sum_{i=1}^n i^2$$

- Now apply your \sum rules

Do any canceling you can with the numbers and n

Multiply out each expression

Write every term over a denominator

Do any canceling you can

This is a formula for the area using n rectangles

$$A = \left(\frac{4}{n}\right)n + \left(\frac{8}{n^2}\right)\frac{n(n+1)}{2} + \left(\frac{8}{n^3}\right)\frac{n(n+1)(2n+1)}{6}$$

$$A = 4 + \frac{4(n+1)}{n} + \frac{4(2n^2 + 3n + 1)}{3n^2}$$

$$A = 4 + \frac{4n}{n} + \frac{4}{n} + \frac{8n^2}{3n^2} + \frac{12n}{3n^2} + \frac{4}{3n^2}$$

$$A = 4 + 4 + \frac{4}{n} + \frac{8}{3} + \frac{4}{n} + \frac{4}{3n^2}$$

- The last step: You want $\lim_{n \rightarrow \infty} A$

Since $\lim_{n \rightarrow \infty} \frac{1}{n} = 0$, all n 's in denominator disappear

So simply add the numbers

$$A = 4 + 4 + \frac{8}{3}$$

$$A = \frac{32}{3}$$

Example 2) Find the area bordered by the curve $f(x) = 6 + x - x^2$, and the lines $x = 1$ and $x = 2$.

Finding the Exact Area Under a Curve - Homework

Find the area between the following curves, the x -axis, between the two given x -values:

1. $f(x) = 4x - 2$, $x = 1$ and $x = 4$ Answer: 24 2. $f(x) = x^2 + x$, $x = 2$ and $x = 4$ Answer: $\frac{74}{3}$

3. $f(x) = 2x^2 - 3x + 1$, $x = 1$ and $x = 2$ Answer: $\frac{7}{6}$ 4. $f(x) = 9 - x^2$ and the x - intercepts Answer: 36

5. $f(x) = x^3$, $x = 0$ and $x = 4$ Answer: 64

The Definite Integral as Area - Classwork

Instead of using the expression “the area under the curve $f(x)$ between $x = a$ and $x = b$, we will now denote a shorthand to represent the same thing. We will use what is called “a definite integral.” The definite integral sign is the same as the indefinite integral sign (\int) but will contain two limits of integration. The form is as follows:

$\int_a^b f(x) dx$. While this does not seem to make much sense, there is a reason for it. The $f(x)$ represents the height of any one rectangle while the dx represents the width of any one rectangle. So $f(x) dx$ means the area of any one rectangle. The integral represents the sum of an infinite number of these rectangles. The a represents the starting place for these rectangles while the b represents the ending place for these integrals.

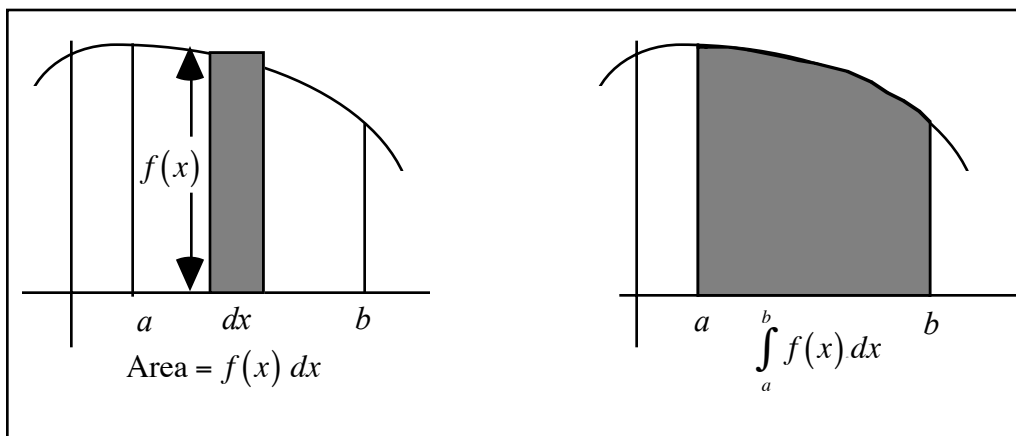

The area of one rectangle = $f(x) dx$

The sum of an infinite number of rectangle areas. Each rectangle is infinitely thin.

When $a < b$, we are determining the area under the curve from left to right. In that case, our dx is a positive number. If $f(x)$ is above the axis, then $\int_a^b f(x) dx$ will be a positive number.

When $b < a$, we are determining the area under the curve from right to left. In that case, our dx is a negative number. If $f(x)$ is above the axis, then $\int_b^a f(x) dx$ will be a negative number. This can be summarized below:

	$f(x) > 0$ (curve above axis)	$f(x) < 0$ (curve below axis)
$dx > 0$ (left to right) ($a < b$)	$\int_a^b f(x) dx > 0$ (Area positive)	$\int_a^b f(x) dx < 0$ (Area negative)
$dx < 0$ (right to left) ($b < a$)	$\int_b^a f(x) dx < 0$ (Area negative)	$\int_b^a f(x) dx > 0$ (Area positive)

Furthermore, there are three more rules which will make sense to you:

1. $\int_a^a f(x) dx = 0$ - If we start at a and end at a , there is no area.
2. $\int_a^b f(x) dx = -\int_b^a f(x) dx$ - From a to b gives an area. From b to a gives the negative of this area.
3. $\int_a^b f(x) dx + \int_b^c f(x) dx = \int_a^c f(x) dx$ - Total the area from a to b , add area from b to c = the area from a to c .

Example) Below you are given the graph of $f(x)$ formed by lines and a semi-circle. Find the definite integrals.

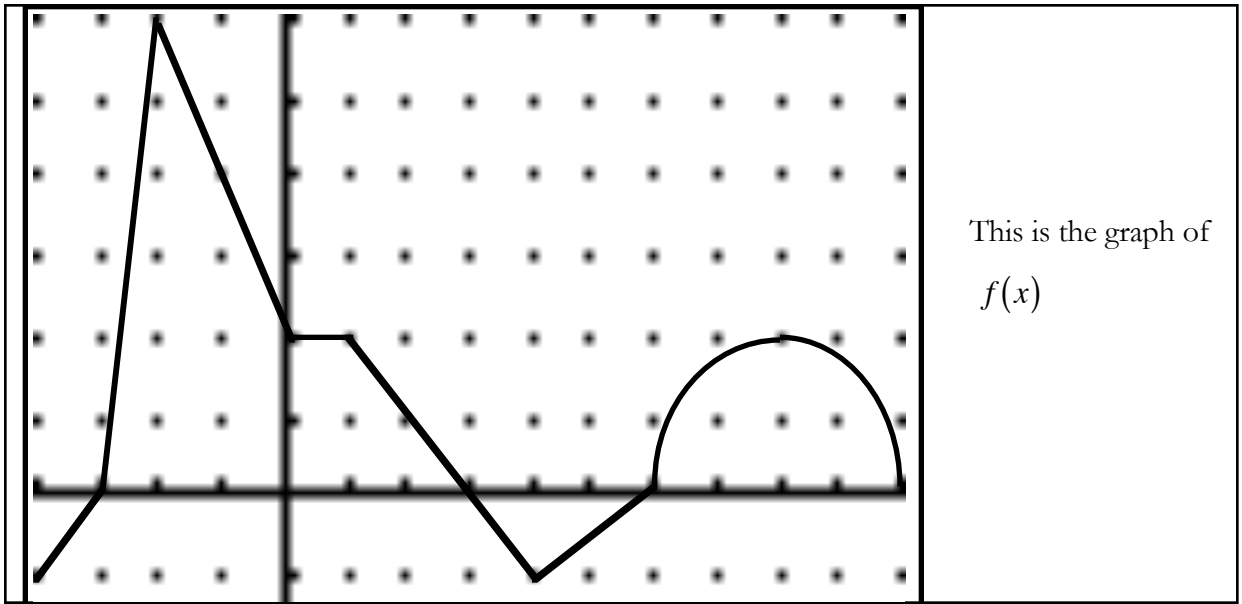

1. $\int_{-4}^4 f(t) dt$

2. $\int_0^1 f(t) dt$

3. $\int_1^3 f(t) dt$

4. $\int_0^3 f(t) dt$

5. $\int_3^6 f(t) dt$

6. $\int_6^3 f(t) dt$

7. $\int_0^6 f(t) dt$

8. $\int_6^{10} f(t) dt$

9. $\int_{10}^6 f(t) dt$

10. $\int_0^{10} f(t) dt$

11. $\int_{10}^0 f(t) dt$

12. $\int_{-1}^0 f(t) dt$

13. $\int_{-3}^0 f(t) dt$

14. $\int_0^{-3} f(t) dt$

15. $\int_{-4}^{-3} f(t) dt$

16. $\int_{-4}^0 f(t) dt$

17. $\int_{-4}^{10} f(t) dt$

18. $\left| \int_0^{10} f(t) dt \right|$

19. $\int_0^{10} |f(t)| dt$

20. $\left| \int_{-4}^{10} f(t) dt \right|$

21. $\int_{10}^{-4} |2f(t)| dt$

Suppose $\int_{-2}^5 f(x) dx = 18$, $\int_{-2}^5 g(x) dx = 5$, $\int_{-2}^5 h(x) dx = -11$ and $\int_{-2}^8 f(x) dx = 0$, find

22. $\int_{-2}^5 (f(x) + g(x)) dx$

23. $\int_{-2}^5 [f(x) + g(x) - h(x)] dx$

24. $\int_5^{-2} 4g(x) dx$

25. $\int_{-2}^5 (g(x) + 2) dx$

26. $\int_{-2}^5 (f(x) - 6) dx$

27. $\int_0^7 h(x - 2) dx$

28. $\int_{-4}^3 g(x + 2) dx$

29. $\int_5^8 f(x) dx$

30. $\int_1^8 [f(x - 3) + 3] dx$

The Definite Integral as Area - Homework

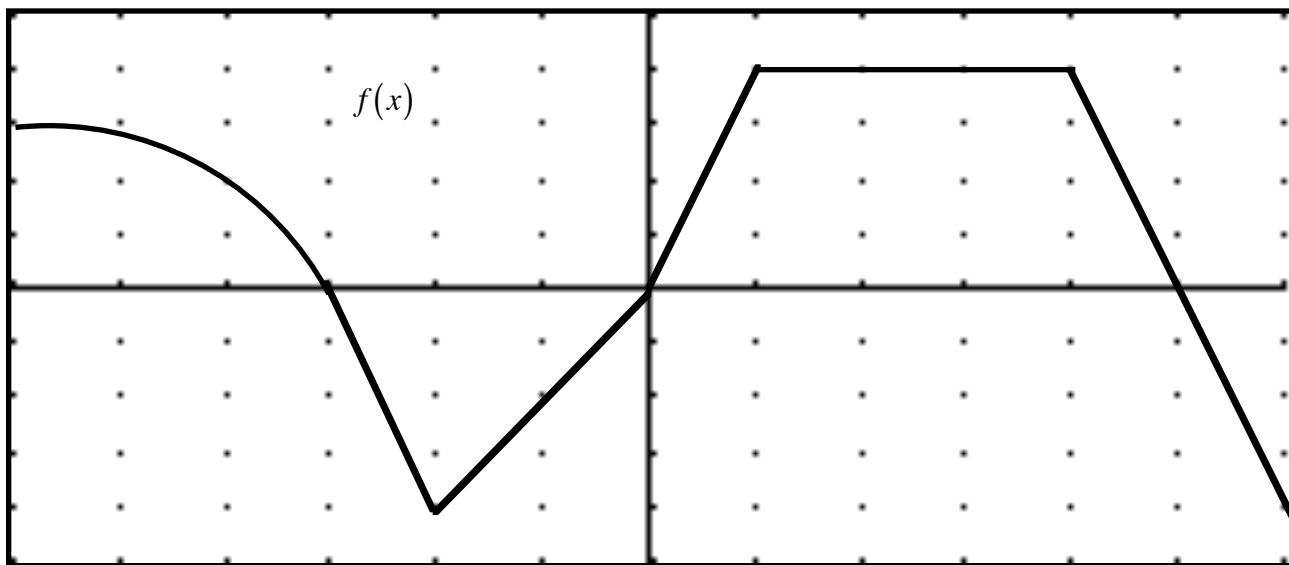

1. $\int_0^1 f(x) dx$

2. $\int_2^4 f(x) dx$

3. $\int_1^4 f(x) dx$

4. $\int_5^5 f(x) dx$

5. $\int_4^5 f(x) dx$

6. $\int_5^6 f(x) dx$

7. $\int_4^6 f(x) dx$

8. $\int_0^6 f(x) dx$

9. $\int_3^2 f(x) dx$

10. $\int_5^0 f(x) dx$

11. $\int_6^0 f(x) dx$

12. $\int_{-3}^0 f(x) dx$

13. $\int_{-3}^0 f(x) dx$

14. $\int_{-3}^2 f(x) dx$

15. $\int_{-3}^4 f(x) dx$

16. $\int_{-6}^{-3} f(x) dx$

17. $\int_{-6}^{-3} f(x) dx$

18. $\int_{-6}^0 f(x) dx$

19. $\int_{-6}^6 f(x) dx$

20. $\int_{-6}^6 f(x) dx$

21. $\left| \int_{-2}^1 f(x) dx \right|$

22. $\int_{-2}^1 |f(x)| dx$

23. $\int_{-2}^1 |-f(x)| dx$

24. $\int_{-6}^6 |f(x)| dx$

Suppose that $\int_0^2 f(x) dx = 2$, $\int_1^2 f(x) dx = -1$, $\int_2^4 f(x) dx = 7$, evaluate the following:

25. $\int_1^4 f(x) dx$

26. $\int_0^4 3f(x) dx$

27. $\int_0^1 f(x) dx$

28. $\int_0^1 f(x+1) dx$

29. $\int_0^2 (f(x) + 3) dx$

30. $\int_2^4 f(x-2) dx$

31. If $\int_0^3 f(x) dx = -1$, find $\int_{-3}^3 f(x) dx$ if f is a) even _____ b) odd _____

The problems on this page and the next should be done without calculators.

32. For each function below, use a sketch of f to evaluate the 4 definite integrals on top given the statement on the left. (a is a positive constant)

	$\int_0^2 f(x) dx$	$\int_1^4 f(x) dx$	$\int_5^1 f(x) dx$	$\left \int_9^{-9} f(x) dx \right $
$f(x) = 3$				
$f(x) = a$				
$f(x) = -\sqrt{a}$				

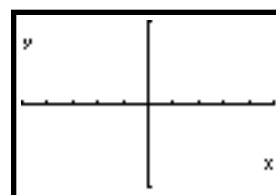
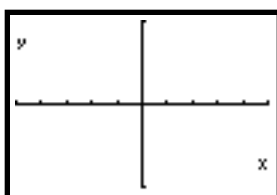
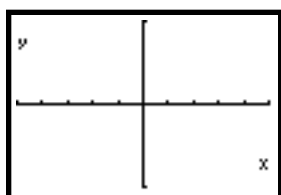

33. Evaluate the following by making a sketch of the function.

a. $\int_{-3}^3 (x+2) dx$

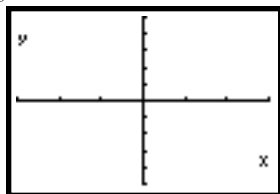

b. $\int_{-3}^3 |x+2| dx$

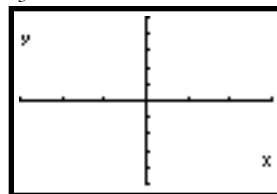

c. $\int_{-3}^3 ||x| + 2| dx$

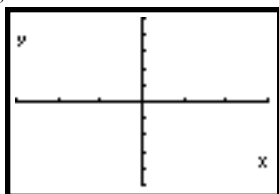

d. $\int_{-3}^3 |2 - |x|| dx$

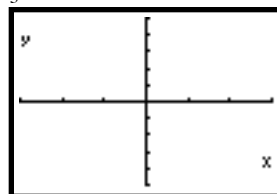

34. Evaluate $\int_0^2 f(x) dx$ where $f(x) = \begin{cases} 1+x, & \text{if } 0 \leq x \leq 1 \\ 2-x, & \text{if } 1 < x \leq 2 \end{cases}$. Make a sketch of the function.

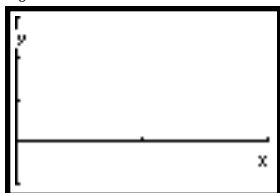

The Accumulation Function - Classwork

Now that we understand that the concept of a definite integral is nothing more than an area, let us consider a very special type of area problem. Suppose we are given a function $f(x) = 2$. We know that to be a horizontal line at $y = 2$. First, realize that the equation of the graph of $f(x) = 2$ is the same as $f(t) = 2$ is the same as $f(k) = 2$. Whether we use x , t , or k , it does not matter. The graph is still a horizontal line. We are used to using x but we will see a good reason that we will occasionally be using another letter.

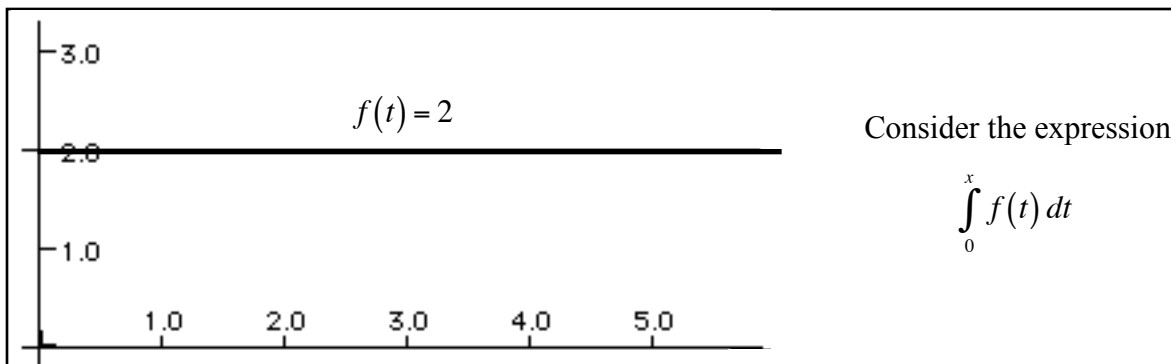

Above, we have the graph $f(t) = 2$. We now want to consider the expression $\int_0^x f(t) dt$. What is this? It is a function of x . As x changes, $\int_0^x f(t) dt$ changes as well. Complete the chart below.

x	0	1	2	3	4	5
$\int_0^x f(t) dt$						

It should be apparent that as x gets bigger, $\int_0^x f(t) dt$ increases as well. What we appear to be doing is

“accumulating area” and we call $\int_0^x f(t) dt$ the accumulation function. Finally, it should be obvious why we use

$f(t) = 2$ to describe our line rather than $f(x) = 2$. $\int_0^x f(x) dx$ would be confusing.

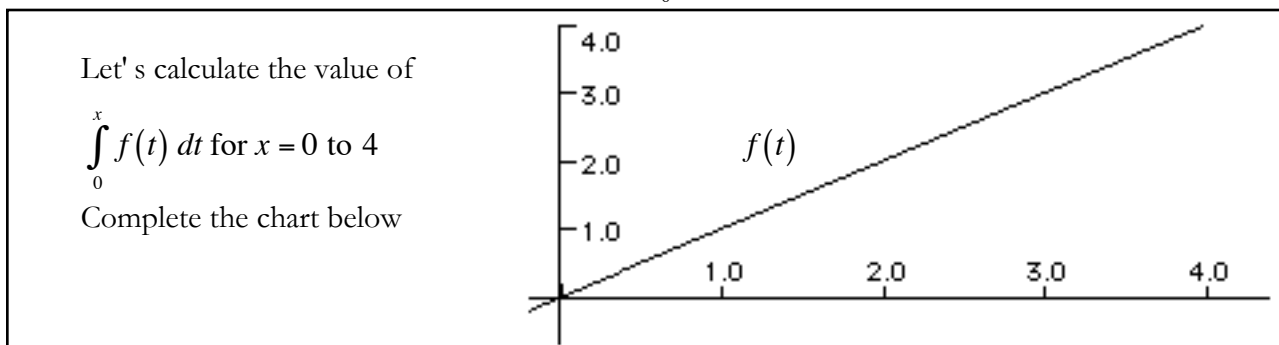

x	0	1	2	3	4
$\int_0^x f(t) dt$					

Example 1) Let $F(x) = \int_0^x f(t) dt$ where the graph of $f(x)$ is below. Remember $f(x)$ is the same thing as $f(t)$.

Think of $f(x)$ as the rate of snowfall over a period of time. For instance, at $x = 1$, snow is falling at 3 inches per hour, at $x = 3$, it is not snowing, and at $x = 4$, snow is melting at 4 inches per hour.

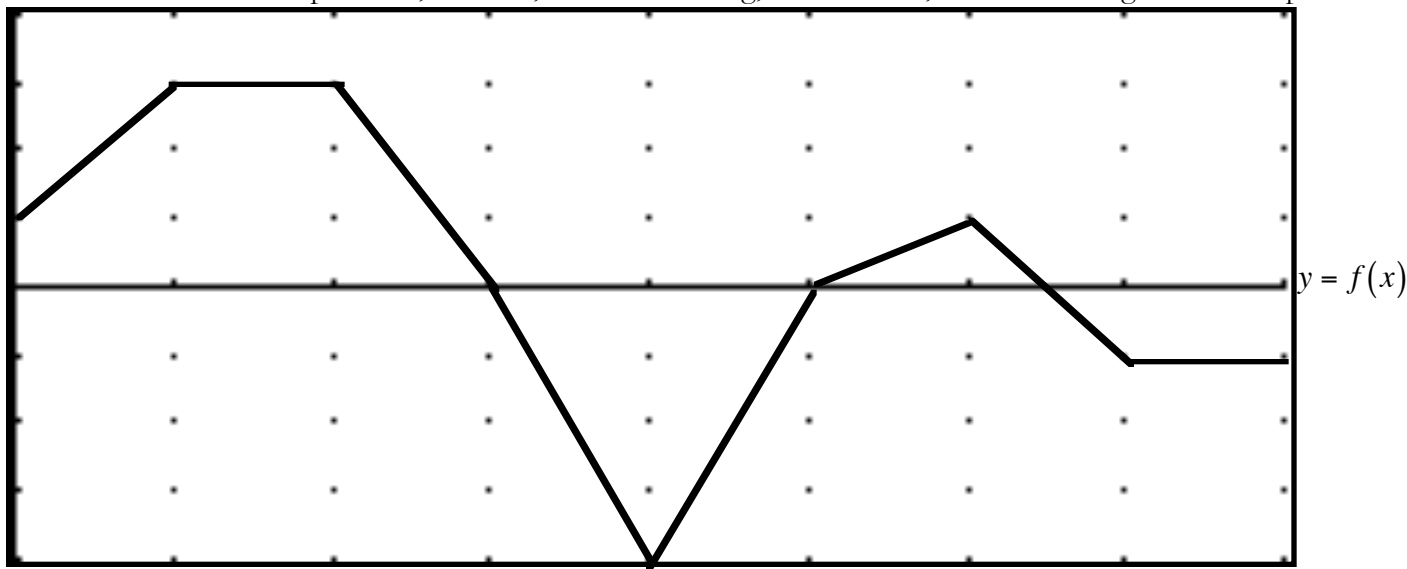

a. Complete the chart. In the snow analogy, $F(x)$ represents the accumulation of snow over time.

x	0	1	2	3	4	5	6	6.5	7	8
$F(x)$										

b. Now let's consider $F'(x) = \frac{d}{dx} \int_0^x f(t) dt$. If we take the derivative of an integral, what would you expect to

happen? _____ So $F'(x) = \frac{d}{dx} \int_0^x f(t) dt$ is the same thing as _____.

Knowing that, let's complete the chart.

x	0	1	2	3	4	5	6	6.5	7	8
$F'(x)$										

c. On what subintervals of $[0, 8]$ is F increasing? Decreasing?

d. Where in the interval $[0, 8]$ does F achieve its minimum and maximum value? What are those values?

f. Find the concavity of F and any inflection points. Justify your answer

h. Sketch a rough graph of $F(x)$

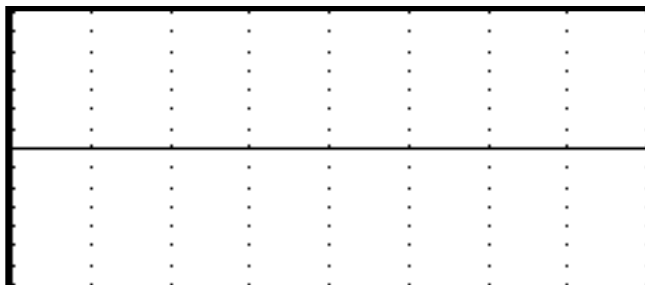

Example 2) Let $F(x) = \int_0^x f(t) dt$ where f is the function graphed below (consisting of lines and a semi-circle)

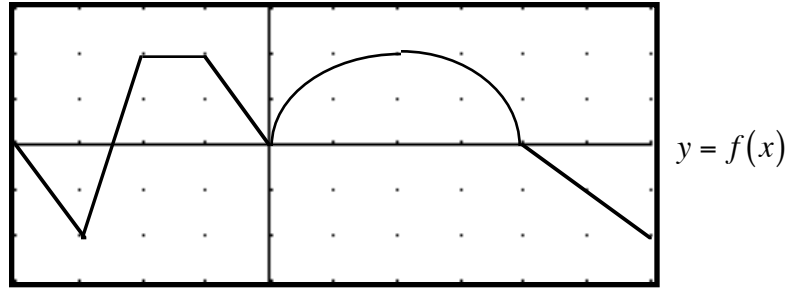

Find the following:

- | | | | |
|------------|------------|------------|-------------|
| a) $F(0)$ | b) $F(2)$ | c) $F(4)$ | d) $F(6)$ |
| e) $F(-1)$ | f) $F(-2)$ | g) $F(-3)$ | h) $F(-4)$ |
| i) $F'(4)$ | j) $F'(2)$ | k) $F'(6)$ | l) $F'(-3)$ |

m) On what subintervals of $[-4,6]$ is F increasing and decreasing. Justify your answer.

n) Where in the interval $[-4,6]$ does F achieve its minimum value? What is the minimum value?

o) Where in the interval $[-4,6]$ does F achieve its maximum value? What is the minimum value?

p) Where on the interval $[-4,6]$ is F concave up? Concave down? Justify your answer.

q) Where does F have points of inflection?

r) Sketch the function F .

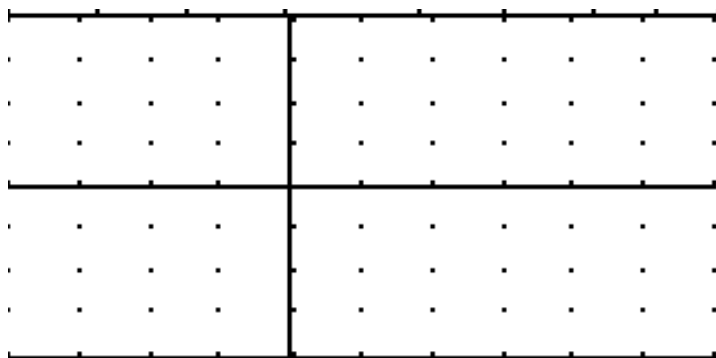

each tic mark
on y-axis is
2 units

The Accumulation Function - Homework

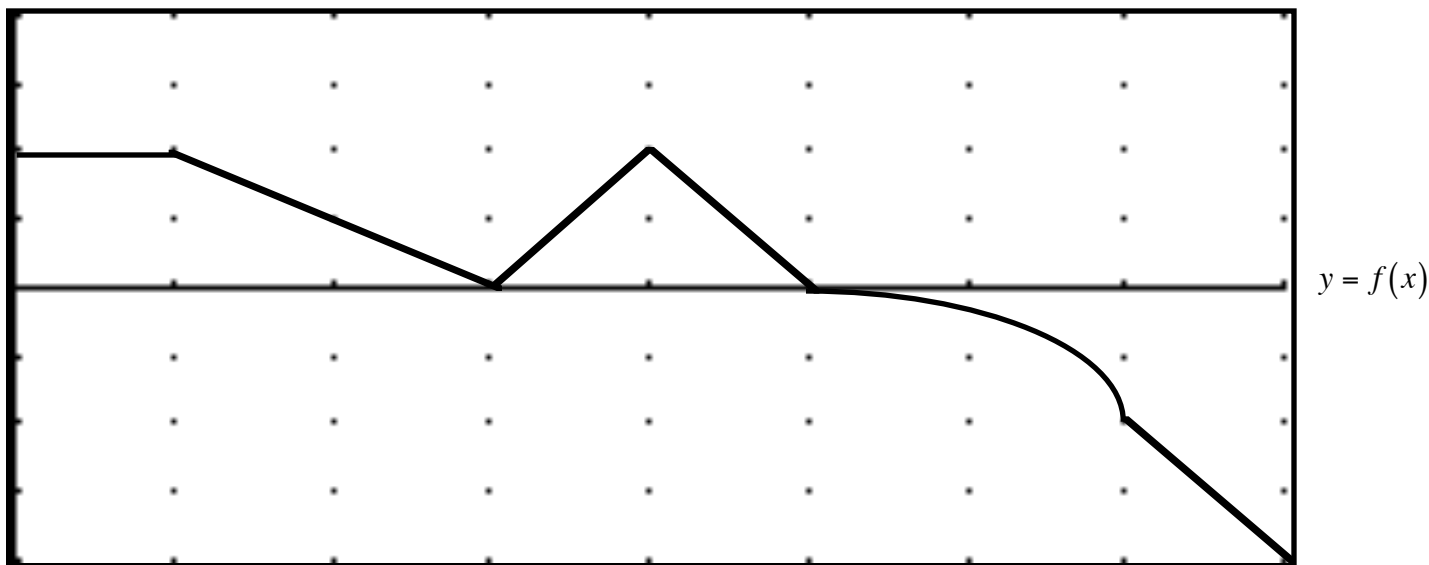

1. Let $F(x) = \int_0^x f(t) dt$ where the graph of $f(x)$ is above (the graph consists of lines and a quarter circle)

a. Complete the chart

x	0	1	2	3	4	5	7	8
$F(x)$								
$F'(x)$								

b. On what subintervals of $[0, 8]$ is F increasing? Decreasing? Justify your answer.

c. Where in the interval $[0, 8]$ does F achieve its minimum value? What is the minimum value? Justify answer.

d. Where in the interval $[0, 8]$ does F achieve its maximum value? What is the maximum value? Justify answer.

e. Find the concavity of F and any inflection points. Justify answers.

f. Sketch a rough graph of $F(x)$

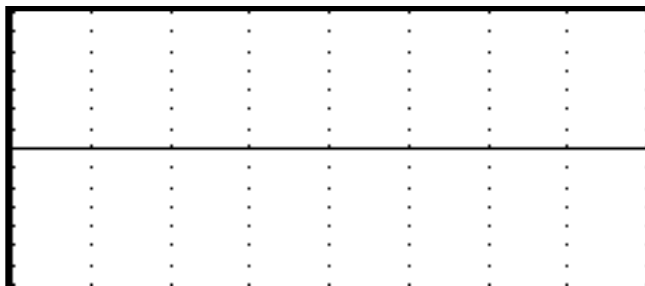

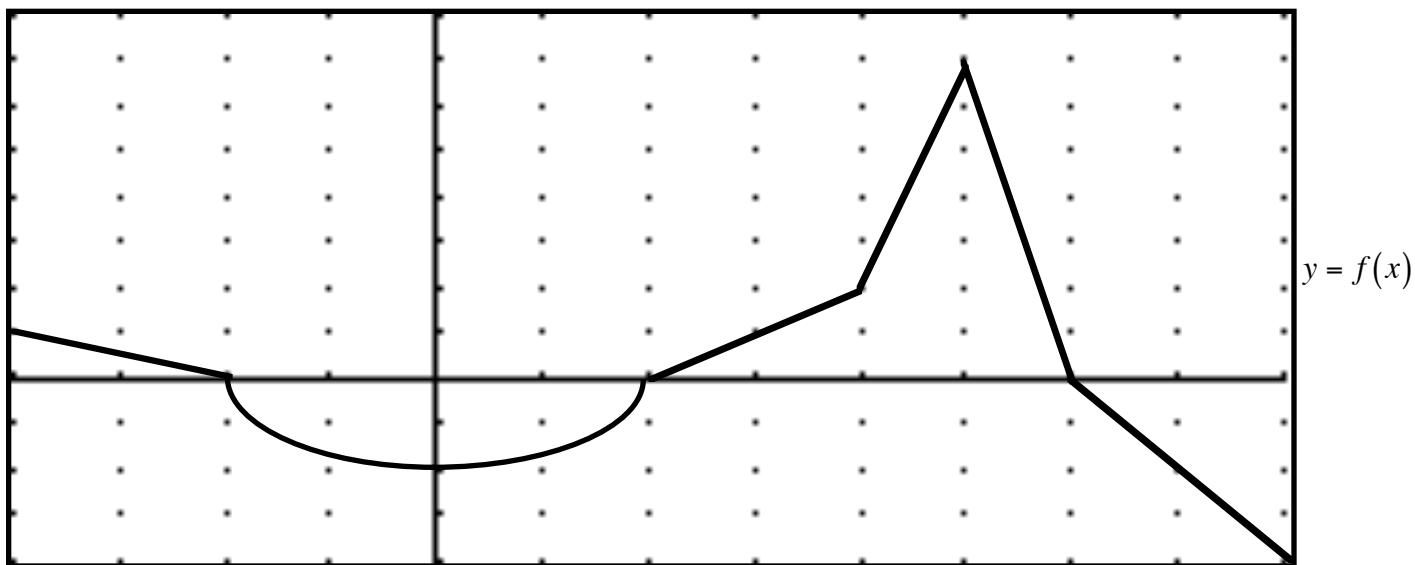

2. Let $F(x) = \int_0^x f(t) dt$ where the graph of $f(x)$ is above (the graph consists of lines and a semi-circle)

a. Complete the chart

x	-4	-3	-2	-1	0	1	2	3	4	5	6	7	8
$F(x)$													
$F'(x)$													

b. On what subintervals of $[-4,8]$ is F increasing? Decreasing?

c. Where in the interval $[-4,8]$ does F achieve its minimum value? What is the minimum value? Justify answer.

d. Where in the interval $[-4,8]$ does F achieve its maximum value? What is the maximum value? Justify answer.

e. On what subintervals of $[-4,8]$ is F concave up and concave down? Find its inflection points. Justify answers.

f. Sketch a rough graph of $F(x)$

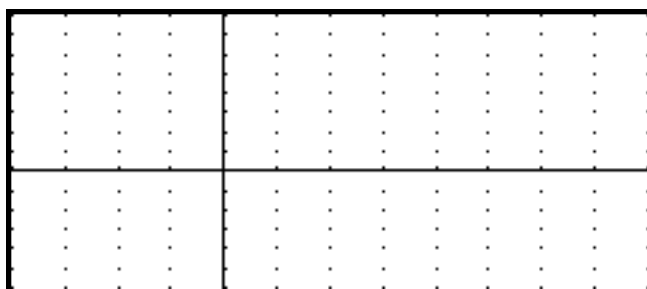

The Accumulation Function - Life Application

You have bought 100 shares of XYZ stock and decide to keep it for 15 days. Below is a graph that represents the change of the price of the your stock on each day. For instance, on the end of day 1, the stock has increased by \$1 a share. At the end of day 4, it has not changed. At the end of day 6, it has gone down by \$3.50 a share.

We will call the graph you see below $f(t)$. made up of straight lines. It is obviously a function of time. Remember that the function represents the *change* in the value of your stock, **not** the value of the stock.

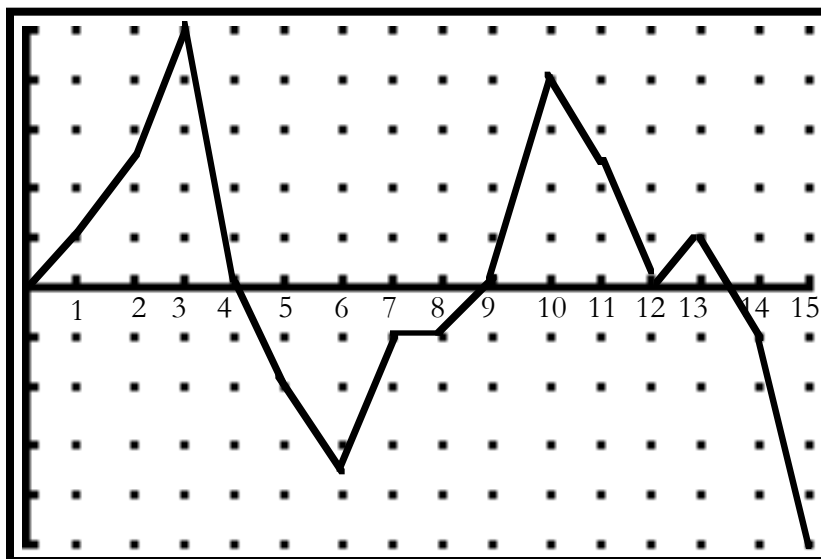

Let $F(x) = \int_0^x f(t) dt$. Answer the following questions:

1. Complete the chart below.

x	0	1	2	3	4	5	6	7	8	9	10	11	12	13	14	15
$f(x)$																
$F(x)$																

2. What is the real life meaning of $F(x)$?

3. For what intervals is $F(x)$ increasing and decreasing. Justify your answer.

4. In the interval $[0, 15]$, find the minimum value of $F(x)$ and the day it is reached. Justify your answer.

5. In the interval $[0, 15]$, find the maximum value of $F(x)$ and the day it is reached. Justify your answer.

6. Determine the concavity of $F(x)$ and justify your answer.

7. Below, sketch $F(x)$.

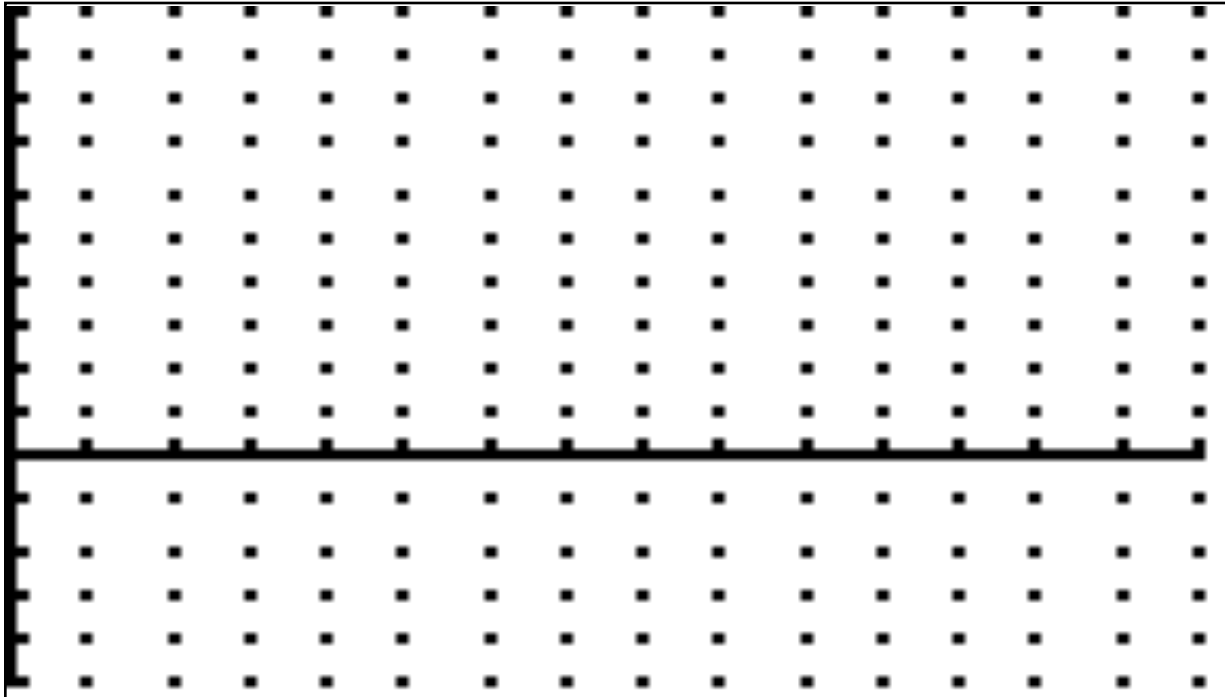

8) Based on your findings, find:

- a) how much money you made(lost) on XYZ stock in that 15 day time period.
- b) the day that the stock's value had the biggest rise
- c) the days between which the stock's value had the steepest rise (not the same question)
- d) the day that the stock's value had the biggest decline
- e) the days between which the stock's value had the steepest decline (not the same question)
- f) the day you wished you sold your stock
- g) the day you are glad you didn't sell your stock

The Fundamental Theorem of Calculus - Classwork

Example 1) On your calculator, graph the function $y = 2x$ on the interval $[0, 6]$. You should get the graph below.

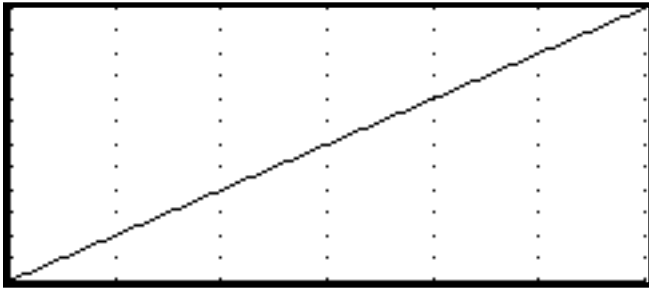

Now let

$$F(x) = \int_0^x 2t \, dt$$

This is the accumulated area under the graph of the function to the left. Complete the chart below.

x	0	1	2	3	4	5	6
$F(x)$							

What is the relationship that you see between x and $F(x)$? _____

So it appears that $\int_0^x 2t \, dt =$ _____

Example 2) On your calculator, graph $y = \cos x$ on the interval $[0, 2\pi]$. You should get the graph below.

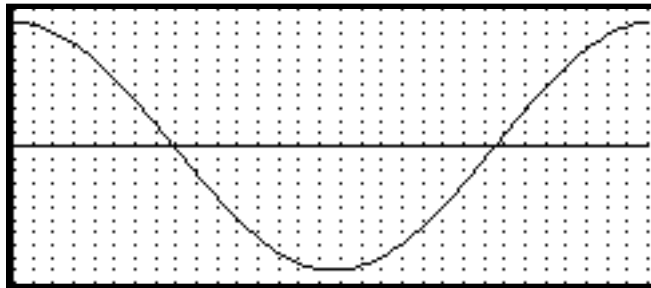

Now let

$$F(x) = \int_0^x \cos t \, dt$$

This is the accumulated area under the curve $y = \cos x$

On your calculator, set your accuracy to 2 decimal places and define Y2 as $\text{FnInt}(Y1, X, 0, X)$. FnInt is located in **Math** 9. Then go to **2nd** **TBLSET**, define TblStart = 0 and Δ Tbl = .2. Then press **2nd** **Table**. Your accumulated area should be located in Y2.

b. We need to get this set of values in to a list. Press **STAT** **EDIT** L1 can be defined as **2nd** **List**

$\text{Seq}(X, X, 0, 6, .2, 2)$. L2 is defined as $Y2(L1)$. It will take a few seconds to compute these values. Now go to **Stat Plot**, turn Plot1 on, and perform a scatterplot with L1 vs. L2

c. Go to **Y=** and turn both Y1 and Y2 off. Now graph the function.

d. Guess the function whose scatterplot you have _____ So it appears that $\int_0^x \cos t \, dt =$ _____

We are now ready to make the connection to area under a curve and indefinite integration introduced earlier. This is accomplished through the Fundamental Theorem of Calculus (Newton and Leibniz).

The Fundamental Theorem of Calculus

If a function f is continuous on the closed interval $[a,b]$, and F is an antiderivative of f on $[a,b]$, then
$$\int_a^b f(x) dx = F(b) - F(a)$$

What the Fundamental Theorem of Calculus (FTC) allows you to do is to find the area under the curve by the process of integration and not having to use the limit of a sum.

Examples) Find the value of the definite integrals below.

1) $\int_1^2 x^2 dx$

2) $\int_{-1}^3 (3x^2 - 2x - 1) dx$

3) $\int_0^9 \sqrt{x} dx$

4) $\int_5^{10} \frac{2}{3x^2} dx$

5) $\int_{-1}^1 (2x - 1)^2 dx$

6) $\int_1^8 \frac{x-2}{\sqrt[3]{x}} dx$

7) $\int_0^{\pi} (2 + \sin x) dx$

8) $\int_0^{\pi/4} (4x + \sec^2 x) dx$

9) $\int_0^5 |4 - 2x| dx$

Technology: Your TI-84 calculators allow you to find the value of a definite integral. The command is FnInt and is located as #9 in the Math menu. The syntax of the statement is FnInt(expression in X, X, lower, upper).

For instance, example # 1 above ... $\int_1^2 x^2 dx$ would be expressed to the calculator as FnInt(X², X,1,2) yielding

2.333. You can also put your expression in Y1 and your statement would be FnInt(Y1, X,1,2). The calculator is finding the integral but not by the Fundamental Theorem of Calculus. It is merely performing the summation of rectangles or trapezoids many many times.

The Fundamental Theorem of Calculus - Homework

Find the value of the definite integrals below. Confirm using your calculator.

$$1. \int_0^1 3x \, dx$$

$$2. \int_{-2}^3 (x-5) \, dx$$

$$3. \int_{-1}^4 (x^2 + 2x - 1) \, dx$$

$$4. \int_0^2 (2x-5)^2 \, dx$$

$$5. \int_2^3 \left(\frac{4}{x^2} + 1 \right) \, dx$$

$$6. \int_{-2}^{-1} \left(x - \frac{1}{x^2} \right) \, dx$$

$$7. \int_1^9 \frac{x-2}{\sqrt{x}} \, dx$$

$$8. \int_{-2}^2 \sqrt[3]{x} \, dx$$

$$9. \int_0^1 \left(t^{2/3} - t^{1/3} \right) \, dt$$

$$10. \int_0^3 |x-2| \, dx$$

$$11. \int_{-\pi/2}^{\pi/2} \cos x \, dx$$

$$12. \int_0^{\pi} (2x - \sin x) \, dx$$

$$13. \int_0^{\pi/2} (3\sin x - 2\cos x) \, dx$$

$$14. \int_0^{\pi/4} (x - \sec^2 x) \, dx$$

$$15. \int_0^{\pi/3} \sec \theta \tan \theta \, d\theta$$

Definite Integration with u-Substitution - Classwork

When you have to find a definite integral involving *u-substitution*, it is often convenient to determine the limits of integration in terms of the variable u , rather than having to integrate and switch back to x and then substitute. This is called “changing the limits.”

Example 1) $\int_0^2 x(x^2 + 1)^2 dx$ Start off by finding u _____ $x = 2, u =$ _____

$\frac{1}{2} \int_0^2 2x(x^2 + 1)^2 dx$ $du =$ _____ Do we have it? $x = 0, u =$ _____

Now write everything in terms of u and calculate. It is no longer necessary to switch back to x .

Example 2) $\int_0^1 x\sqrt{1-x^2} dx$

Example 3) $\int_0^{\sqrt{5}} \frac{x}{\sqrt{x^2 + 4}} dx$

Example 4) $\int_0^{\pi/4} \sin 2x dx$

Example 5) $\int_0^{\pi/2} \sin x \sqrt{\cos x} dx$

Example 6) $\int_0^{\pi/6} (1 + \sin x \cos x) dx$

Example 7) $\int_{-2}^2 |1 - x^2| dx$

Definite Integration with u-Substitution - Homework

Find the values of the following definite integrals. Verify using your calculator. Some will use u -substitution, others will not.

$$1. \int_{-2}^2 (x^3 - 1) dx$$

$$2. \int_0^4 x(\sqrt{x} - 1) dx$$

$$3. \int_0^{\pi/3} \sin(2x) dx$$

$$4. \int_0^{\pi/12} (1 - \cos 2x) dx$$

$$5. \int_0^1 2x(x^2 + 1)^2 dx$$

$$6. \int_0^3 x\sqrt{9 - x^2} dx$$

$$7. \int_0^5 |x - 4| dx$$

$$8. \int_0^4 |x - \sqrt{x}| dx$$

$$9. \int_2^3 \frac{x}{(x^2 - 3)^2} dx$$

$$10. \int_0^4 \frac{dt}{\sqrt{2t+1}}$$

$$11. \int_0^{\pi/2} \cos^3 t \sin t dt$$

$$12. \int_0^{\sqrt{\pi/2}} t \sin(\pi - t^2) dt$$

$$13. \int_0^{\pi/4} \sqrt{\tan x} \sec^2 x \, dx$$

$$14. \int_0^{\pi/3} \cos x \sqrt{1 - \cos^2 x} \, dx$$

$$15. \int_0^1 x \sqrt{ax^2 + b} \, dx$$

$$16. \int_{\pi^2/4}^{\pi^2} \frac{\sin \sqrt{x}}{\sqrt{x}} \, dx$$

$$17. \int_0^4 |9 - x^2| \, dx$$

$$18. \int_{-4}^4 \frac{1}{x^2} \, dx \text{ (Be careful!)}$$

If $\int_0^2 f(x) \, dx = \frac{11}{3}$ and $\int_0^6 f(x) \, dx = 15$, $f(x)$ is an even function (symmetric to the y -axis), find the following:

$$19. \int_{-2}^0 f(x) \, dx$$

$$20. \int_{-2}^2 f(x) \, dx$$

$$21. \int_0^2 -f(x) \, dx$$

$$22. \int_{-2}^0 3f(x) \, dx$$

$$23. \int_0^2 f(3x) \, dx$$

If $\int_0^2 f(x) \, dx = \frac{11}{3}$ and $\int_0^6 f(x) \, dx = 15$, $f(x)$ is an odd function (symmetric to the origin), find the following:

$$24. \int_{-2}^0 f(x) \, dx$$

$$25. \int_{-2}^2 f(x) \, dx$$

$$26. \int_0^2 -f(x) \, dx$$

$$27. \int_{-2}^0 3f(x) \, dx$$

$$28. \int_{-2}^2 f(3x) \, dx$$

Straight Line Motion - Revisited - Classwork

When we looked at straight line motion in our derivative section, we generated a relationship between position, velocity, and acceleration. Given position function $s(t)$, the velocity function $v(t) = s'(t)$ and the acceleration function $a(t) = v'(t) = s''(t)$. We can now move in the opposite direction as well. If you have an object traveling in a straight line, its velocity can be written as $v(t) = \int a(t) dt + C$.

Examples) Find $v(t)$ given $a(t)$ and $v(0)$

1) $a(t) = 4t - 6$ and $v(0) = 3$

2) $a(t) = \sin t + 2t$ and $v(0) = 5$

We now define two terms: distance: how far you travel between time $t = a$ and time $t = b$.

displacement: the difference in distance from where you start and where you stop.

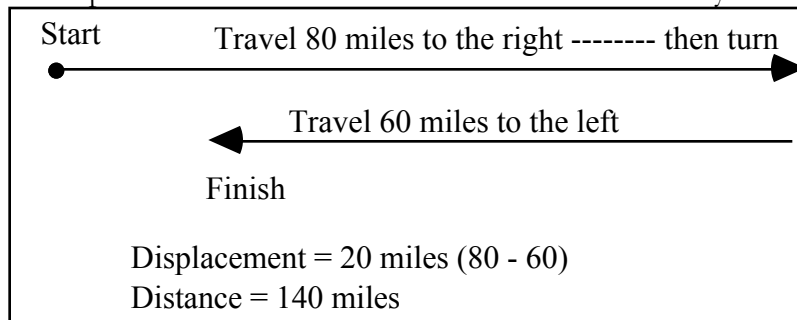

Can displacement equal distance? How? _____

So if we are given a velocity function which is always positive, we know that distance = displacement. But if the velocity function is not always positive, we must find when the time interval when the velocity is negative (moving backwards) so we can find the distance traveled in that interval and subtract it (which will be subtracting a negative number or adding a positive one). This can be summarized as:

Given a particle moving on a straight line with velocity $v(t)$ between time $t = a$ and time $t = b$. Then

$$\text{Displacement} = \int_a^b v(t) dt \qquad \text{Distance} = \int_a^b |v(t)| dt$$

Example 3) A particle is moving along a straight line with velocity $v(t) = t^2 - 7t + 10$ (ft/sec) Find the displacement and distance traveled on the time interval $[1, 7]$

Displacement (easy)

Distance (more difficult)

This can be confirmed using the calculator.

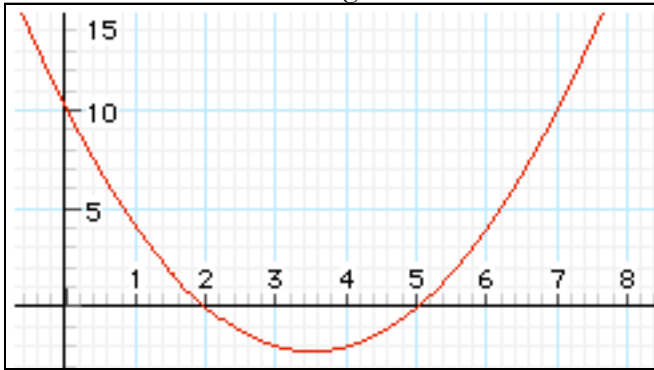

This is the graph of $v = t^2 - 7t + 10$, notice that v is negative (going backward) between $t = 2$ and $t = 5$. When you take the integral $\int_1^7 (t^2 - 7t + 10) dt$, this will be taken into account.

If you are allowed to use your calculator, you use $\text{FnInt}(X^2-7X+10,X,1,7)$

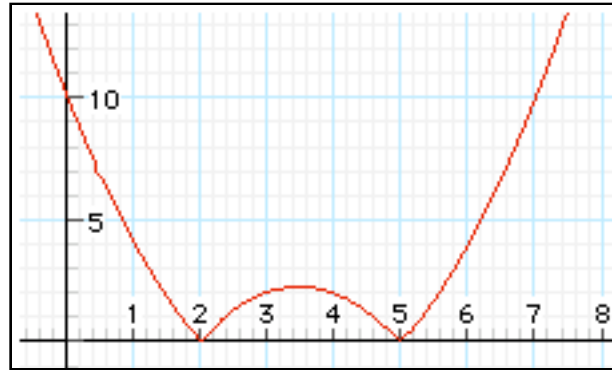

This is the graph of $v = |t^2 - 7t + 10|$. Note that between $t = 2$ and $t = 5$, the function is now above the axis and distance is positive. So the integral is

$$\int_1^7 |t^2 - 7t + 10| dt = \int_1^2 (t^2 - 7t + 10) dt - \int_2^5 (t^2 - 7t + 10) dt + \int_5^7 (t^2 - 7t + 10) dt$$

If you are allowed to use your calculator, you use $\text{FnInt}(\text{abs}(X^2-7X+10),X,1,7)$

Example 4) Given an object moving in a straight line with $a(t) = \sqrt{t} \frac{\text{ft}}{\text{sec}^2}$, $v(0) = -18$, $t = 0$ to $t = 16$, find $v(t)$ and the displacement and distance of the object.

Example 5) A subway train accelerates as it leaves one station, then decelerates as it comes into the next station. following chart measures the velocity v given in miles per hour .

time t (sec)	0	5	10	15	20	25	30	35	40	45	50	55	60
velocity	0	15	33	42	44	44	44	44	43	38	24	8	0
Distance													

- find the distance the train travels every 5 second interval.
- find the total distance between subway stops.

Straight Line Motion - Revisited - Homework

Given the velocity of an object in ft/sec, find the displacement and distance traveled in the given time interval.

1. $v(t) = 12 - 3t$ $[0, 5]$

2. $v(t) = t^2 - 10t + 16$ $[0, 6]$

Given the acceleration of an object in ft/sec² and its initial velocity, find the displacement and distance traveled in the given time interval.

3. $a(t) = 4t, v(0) = -8$ $[0, 3]$

4. $a(t) = 6\sin t, v(0) = -9$ $[0, \pi]$

- 5) When a model rocket is launched, the propellant burns for a few seconds, accelerating the rocket upward. After burnout the rocket coasts upward for awhile and then begins to fall. A small explosive charge pops out a parachute while the rocket is on its way down. The parachute slows the rocket to keep it from smashing when it lands. The velocity function is given below. Using your calculator, sketch it. Questions a through g should be answered by looking at your graph. Question h) and i) need graphing calculators.

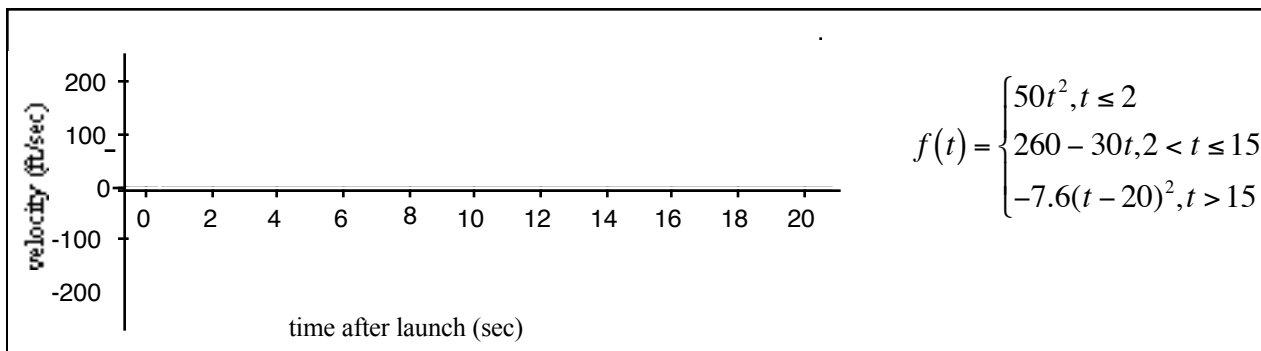

- a. For how many seconds did the engine burn? _____
- b. How fast was the rocket going when the engine stopped? _____
- c. When did the rocket reach its highest point? _____
- d. When did the parachute pop out? _____
- e. How long did the rocket fall before the parachute opened? _____
- f. How fast was the rocket falling when the parachute opened? _____
- g. When was the rocket's acceleration the greatest? _____
- h. Assuming the rocket does land how far does it travel? _____
- i) At what time after launch did the rocket land? _____

Average Value of a Function & 2nd Fund. Thm. - Classwork

On the graph below left, $f(x)$, we know that the area under the curve between 0 and 2 is $\int_0^2 f(x) dx$. The question is, is there a rectangle whose base is 2 which is exactly equal to this integral? Clearly, the area under the rectangle below right is smaller than the area under $f(x)$.

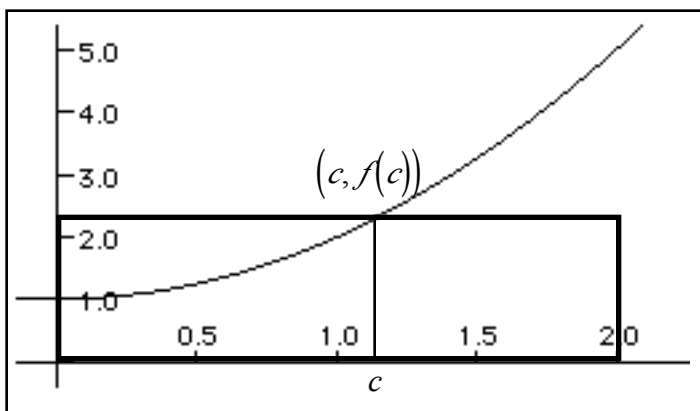
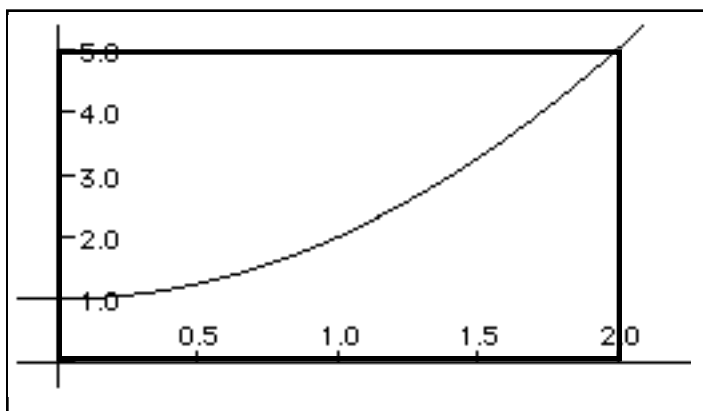
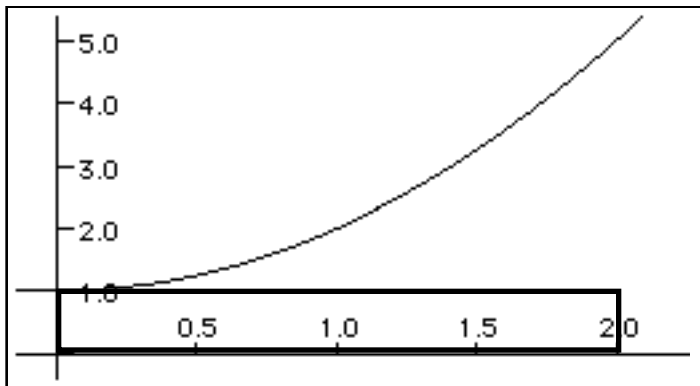
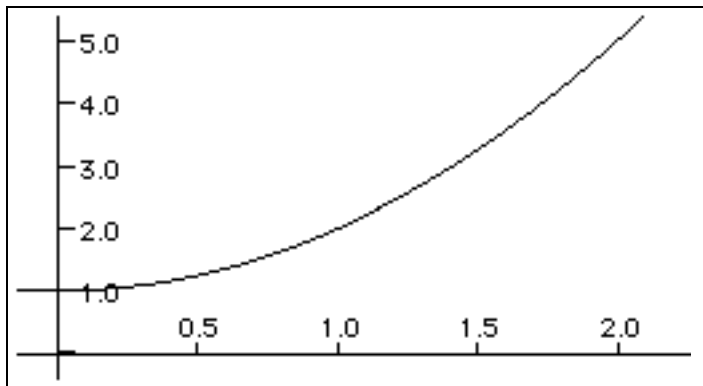

Clearly, the area under the rectangle is greater than the area under the curve $f(x)$.

The area under the curve in this picture is now fairly close to the area under the rectangle.

This can be summarized by the **Mean Value Theorem for Integrals** (not to be confused with the MVT for derivatives).

If f is continuous on the closed interval $[a, b]$, then there exists a number c on $[a, b]$ such that

$\int_a^b f(x) dx = f(c)(b - a)$. What this says is that the area under the curve between a and b can be expressed as the base of the rectangle $(b - a)$ times the height of the rectangle at some point $(c, f(c))$.

Since $\int_a^b f(x) dx = f(c)(b - a)$, we can write $\frac{\int_a^b f(x) dx}{b - a} = f(c)$. This $\frac{\int_a^b f(x) dx}{b - a}$ is called the average value of a function. It represents the height of the rectangle guaranteed by the MVT for integrals.

Example 1) Given $f(x) = x^2 + 1$ on the interval $[0, 2]$ (the problem on the previous page), find
 a) the average value of the function b) the value of c guaranteed by the MVT for integrals.

Example 2) Given $f(x) = \sin x$ on the interval $[0, \pi]$, find
 a) the average value of the function b) the value of c guaranteed by the MVT for integrals.

Suppose you were asked to find $\int_1^x (t^2 - 4t + 1) dt$. Use the Fundamental Theorem of Calculus to do so.

Now, take the derivative of your answer. _____. What is the basic result? _____

The Second Fundamental Theorem of Calculus.

If f is continuous on an open interval I containing a , then, for every x in the interval,

$$\frac{d}{dx} \left[\int_a^x f(t) dt \right] = f(x) \text{ and } \frac{d}{dx} \left[\int_a^u f(t) dt \right] = f(u) \frac{du}{dx}$$

What this says that the constant on the bottom doesn't matter when we take the derivative of an integral. The derivative of the integral is the original integrand (but with the variable changed).

Example 3) Find the following.

a. $\frac{d}{dx} \left[\int_1^x \sqrt{t^2 - 1} dt \right]$

b. $\frac{d}{dx} \left[\int_x^3 t \sin t dt \right]$

c. $\frac{d}{dx} \left[\int_{\pi/2}^{x^2} \cos t dt \right]$

Average Value of a Function & 2nd Fund. Thm. - Homework

1. Find the average value of the function f on the given interval. Do not use calculators.

a) $f(x) = x^2 - 2x$ $[0, 3]$

b) $f(x) = \cos x$ $\left[0, \frac{\pi}{2}\right]$

c) $f(x) = \sqrt{x}$ $[1, 9]$

d) $f(x) = \frac{1}{x^2}$ $[1, 5]$

2. Find the value of x guaranteed by the Mean Value Theorem for Integrals. No calculators on a) and b).

a) $f(x) = 4 - x^2$ $[0, 2]$

b) $f(x) = 4x - x^2$ $[0, 3]$

c) $f(x) = x^3 - x + 1$ $[0, 2]$

d) $f(x) = x \sin x^2$ $[0, \sqrt{\pi}]$

3. Find the numbers b such that the average value of $f(x) = 2 + 7x - x^3$ on the interval $[0, b]$ is equal to 3.

4. In a certain city, the temperature (in °F) t hours after 9 A.M is approximated by the function

$$T(t) = 50 + 14 \sin \frac{\pi t}{12}. \quad \text{Find the average temperature during the time period 9 AM to 9 PM.}$$

5. Show that the Second Fundamental Theorem of Calculus holds for $F(x) = \int_1^x \frac{2}{t^2} dt$. Take the integral, then take the derivative.

6. Use the Second Fundamental Theorem of Calculus to find the derivatives of the following functions.

a) $f(x) = \int_1^x (t^2 + 1)^{20} dt$

b) $g(x) = \int_{-1}^x \sqrt{t^3 + 1} dt$

c) $g(x) = \int_{\pi}^x \frac{1}{1+t^4} dt$

d) $f(x) = \int_4^{x^2} \cos(t^2) dt$

7. Find the interval on which the curve $y = \int_0^x (t^3 + t^2 + 1) dt$ is concave up. Justify your answer.

Area of a Region Between Two Curves - Classwork

Consider two functions f and g that are continuous on $[a, b]$. If the graphs of both functions are above the x -axis and $f(x) \geq g(x)$, we can find the area between the two graphs as the area of the region under the graph of f subtracted from the area of g . Picture below left. The area of a represented rectangle is width times height. The base is Δx and the height of the rectangle is $f(x) - g(x)$. So the area of the rectangle is $(f(x) - g(x)) \Delta x$. As Δx goes to zero, we have a Riemann sum - $\lim_{n \rightarrow \infty} \left[\sum_{i=1}^n (f(x_i) - g(x_i)) \Delta x \right]$ which we know to be $A = \int_a^b [f(x) - g(x)] dx$.

So we say that the area of the shaded region is $A = \int_a^b [f(x) - g(x)] dx$. Now suppose the curves are not both above the x -axis? Explain why that doesn't make a difference. _____

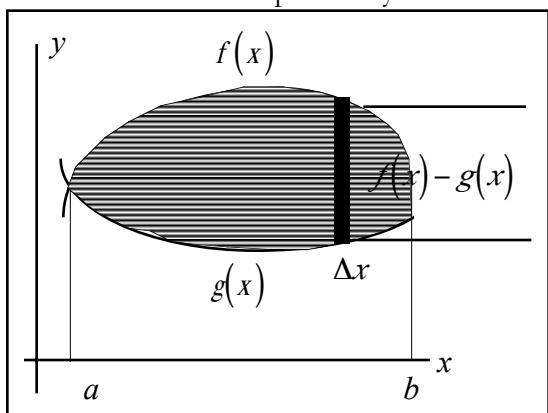

$$A = \int_a^b [f(x) - g(x)] dx$$

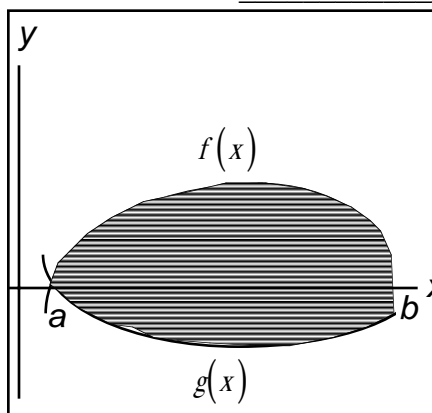

$$A = \int_a^b [f(x) - g(x)] dx$$

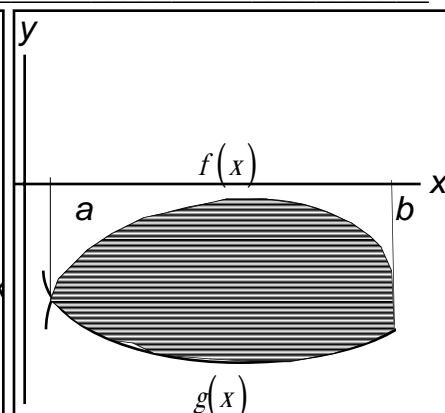

$$A = \int_a^b [f(x) - g(x)] dx$$

As we go through problems in this section, we will use extensively the calculator's ability to find numerical integrals. We will not go through the FTC - integrating and plugging in the top and bottom limits. On the A.P. test, you are allowed to use the calculator's ability to numerically integrate as long as you show the proper setup.

Example 1) Find the region bounded by the graphs of $y = x^2 + x + 2$, $y = -x$, $x = 0$ and $x = 1$.
First sketch it.



The integral is _____

The area is _____

Example 2) Find the region bounded by the graphs $y = 6 - x^2$ and $y = x$. Sketch it.
To integrate, we must find intersections.

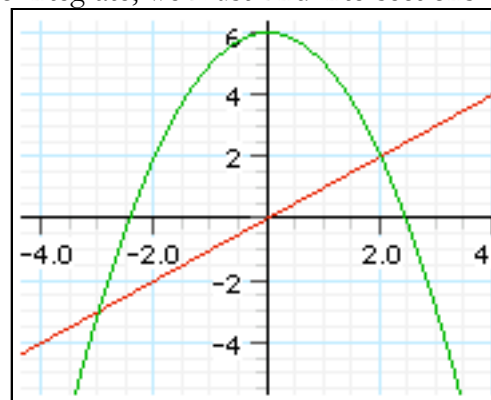

The integral is _____

The area is _____

Example 3) Find the region bounded by the graphs $x = 0$, and the first intersection of $y = \sin x$ and $y = \cos x$.



Your first job is to find the intersection of these two curves. Do it algebraically.

The integral is _____

The area is _____

Example 5) Find the region bounded by the graphs $y = 12 - x^2$, $y = -x$, and $y = 4x$.

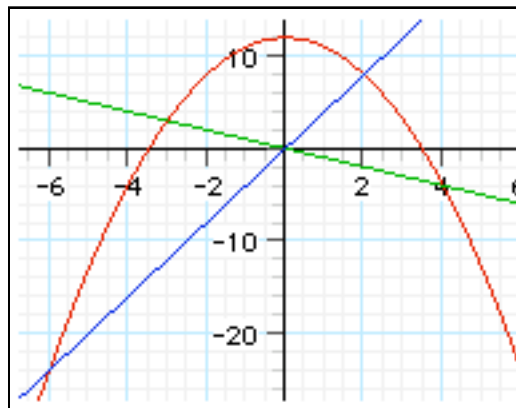

Shade the region you are trying to find.

The integral is _____

The area is _____

Example 4) Find the region bounded by $y = 2x^3 - x^2 - 14x$ and $y = 4x - x^2$. Sketch it noting which curve is on top.

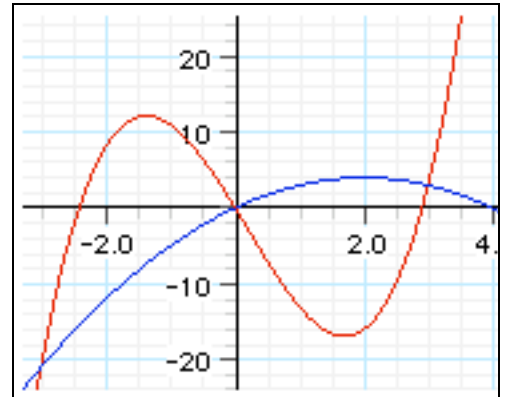

Find the intersections.

The integral is _____

The area is _____

Example 6) Find the region bounded by $x = 3 - y^2$ and $x = y + 1$. To graph it, you need solve for y .

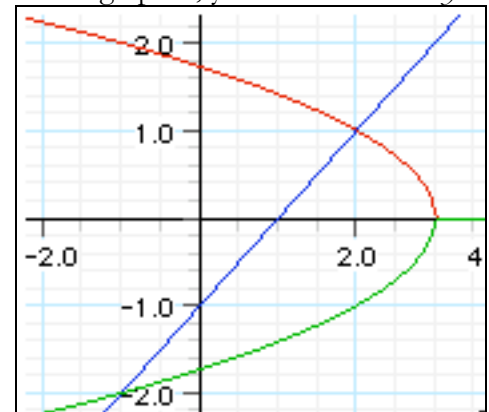

Rather than integrating using x , use y and go right to left instead of top to bottom

The integral is _____

The area is _____

Example 7. On the graph below, choose 3 points at random, draw the triangle, and find its area.

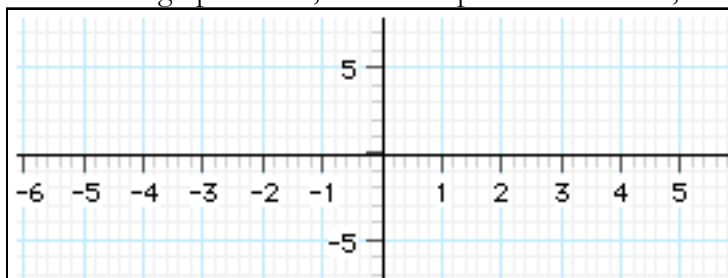

Area of a Region Between Two Curves - Homework

For each problem, sketch the region bounded by the graphs of the functions and find the region of the area.

1. $y = x^2 + 2x + 1, y = 2x + 5$



Integral: _____
Area: _____

2. $y = x^2 - 4x + 3,$
 $y = -x^2 + 2x + 3$



Integral: _____
Area: _____

3. $y = x^2$
 $y = x^3$



Integral: _____
Area: _____

4. $y = (x - 1)^3, y = x - 1$



Integral: _____
Area: _____

5. $y = \frac{1}{x^2}, y = 0, x = 1, x = 5$



Integral: _____
Area: _____

6. $y = \sqrt{3x + 1}, y = x, x = 0$



Integral: _____
Area: _____

7. $y = \sqrt[3]{x}, y = x$



Integral: _____
Area: _____

8. $x = 2y - y^2, x = -y$



Integral: _____
Area: _____

9. $y = \frac{1}{1 + x^2}, y = \frac{1}{2}x^2$



Integral: _____
Area: _____

10. $y = 2 \sin x, y = \tan x$
 $-\frac{\pi}{3} \leq x \leq \frac{\pi}{3}$



Integral: _____

Area: _____

11. $y = 2 \sin x, y = \cos 2x$
 $0 \leq x \leq \pi$



Integral: _____

Area: _____

12. $y = x^3$ and the tangent
line to y at $(1,1)$



Integral: _____

Area: _____

13. Find the value of b if the vertical line $x = b$ divides the region between $x = y = 16 - 2x$ and the x and y -axis into 2 equal areas.

14. Use integration to find the area of the triangle having the vertices $(3, -2)$, $(5, 7)$, and $(7, 2)$.

15. Show that the area under the function $y = ax^2 [-a, a]$ is $\frac{1}{3}$ of the area of the circumscribed rectangle.

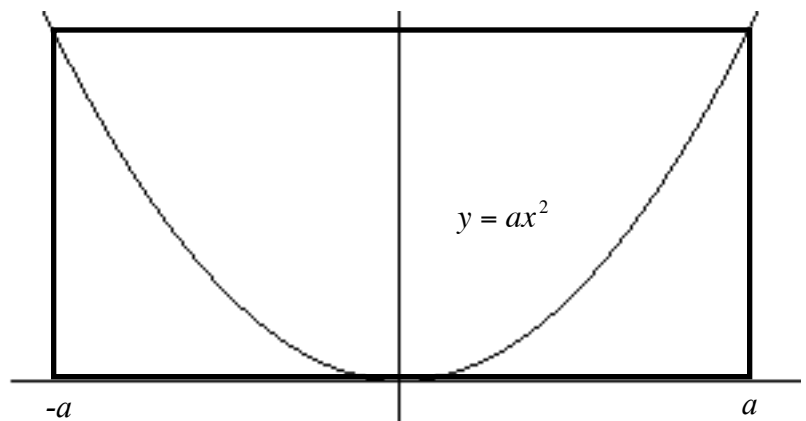

Volume by Disk/Washers - Classwork

1st problem: You are given the function $y = f(x)$ and you are looking at between $x = a$ and $x = b$. You are then going to rotate the function about the x -axis. The 3-D object you get appears like the one below. We wish to find the volume of the object. If you are to look at a cross section by slicing it perpendicular to the x -axis, we get a circle. The formal name for this circle is a **disk**. The area of this disk is πR^2 where R is the radius of the disk. In reality though, this disk is a 3-D shape with a width of Δx . So the volume of a representative disk is $\pi R^2 \cdot \Delta x$. If we take thinner and thinner disks, Δx gets close to zero. So the volume of the solid is $\lim_{n \rightarrow \infty} \sum_{i=1}^n \pi R_i^2 \cdot \Delta x$ which we know to be a Riemann sum. Our job is to find R . The way we will do this is to draw the Radius and label the endpoint as (x, y) . So we end up with the disk formula: $V = \pi \int_a^b R^2 dx$

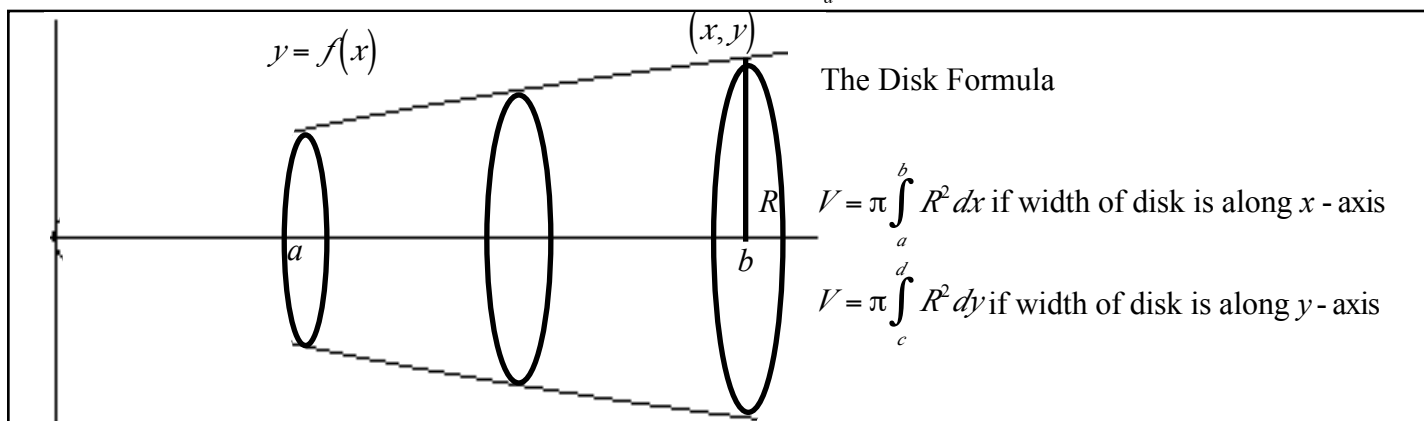

2nd problem: The problem remains the same except the region between two curves are rotated about the x -axis. Instead of creating a disk, we create a washer (2 concentric circles with “air” in between) Using the same argument, the area of the washer is $\pi(R^2 - r^2)$ where R is the outside radius and r is the inside radius. So, we end up with $V = \pi \int_a^b (R^2 - r^2) dx$

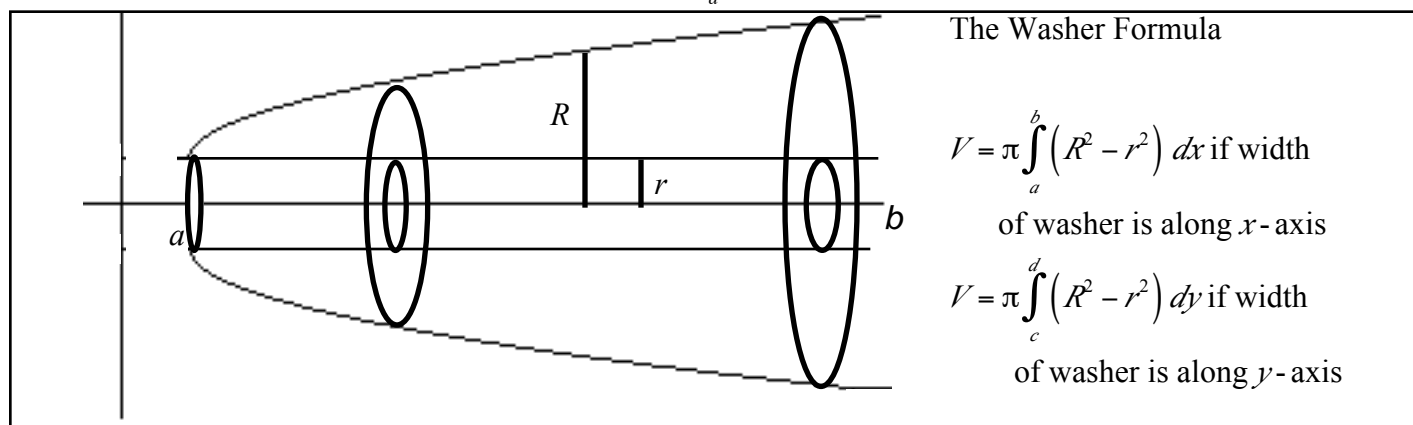

Generalizations:

1. Draw the function (s).
2. Determine the region to rotate.
- 3a. If it is rotated about the x -axis or any horizontal line, it is a dx problem and everything must be in terms of x .
- 3b. If it is rotated about the y -axis or any vertical line, it is a dy problem and everything must be in terms of y .
- 4a. If it is a disk problem, you need to find R .
- 4b. If it is washer problem, you need to find R and r .
5. When in doubt, label the point on the disk/washer as (x, y) . y is a vertical distance and x is a horizontal distance.

Example 1) Find the volume if the region enclosing $y = 2x, y = 0, x = 3$ is rotated about the

a) x -axis



$R = \underline{\hspace{2cm}}$ $r = \underline{\hspace{2cm}}$

$V = \underline{\hspace{2cm}}$

b) the line $y = 6$



$R = \underline{\hspace{2cm}}$ $r = \underline{\hspace{2cm}}$

$V = \underline{\hspace{2cm}}$

c) the line $y = 8$



$R = \underline{\hspace{2cm}}$ $r = \underline{\hspace{2cm}}$

$V = \underline{\hspace{2cm}}$

d) the y -axis



$R = \underline{\hspace{2cm}}$ $r = \underline{\hspace{2cm}}$

$V = \underline{\hspace{2cm}}$

e) the line $x = 3$



$R = \underline{\hspace{2cm}}$ $r = \underline{\hspace{2cm}}$

$V = \underline{\hspace{2cm}}$

f) the line $x = 4$



$R = \underline{\hspace{2cm}}$ $r = \underline{\hspace{2cm}}$

$V = \underline{\hspace{2cm}}$

Example 2) Find the volume if the region enclosing $y = x - 1, y = 0, x = 3$ is rotated about the

a) x -axis

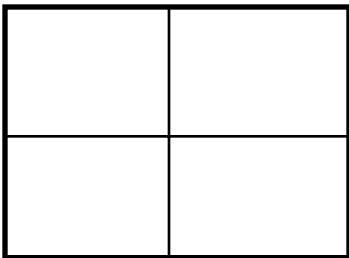

$R = \underline{\hspace{2cm}}$ $r = \underline{\hspace{2cm}}$

$V = \underline{\hspace{2cm}}$

b) the line $y = 2$



$R = \underline{\hspace{2cm}}$ $r = \underline{\hspace{2cm}}$

$V = \underline{\hspace{2cm}}$

c) the line $y = 3$



$R = \underline{\hspace{2cm}}$ $r = \underline{\hspace{2cm}}$

$V = \underline{\hspace{2cm}}$

d) the y -axis

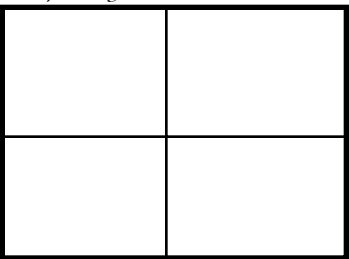

$R = \underline{\hspace{2cm}}$ $r = \underline{\hspace{2cm}}$

$V = \underline{\hspace{2cm}}$

e) the line $x = 3$

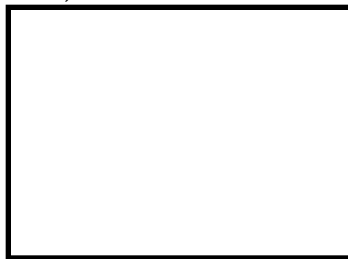

$R = \underline{\hspace{2cm}}$ $r = \underline{\hspace{2cm}}$

$V = \underline{\hspace{2cm}}$

f) the line $x = 5$



$R = \underline{\hspace{2cm}}$ $r = \underline{\hspace{2cm}}$

$V = \underline{\hspace{2cm}}$

Example 3) Find the volume if the region enclosing $y = x^2, y = 0, x = 2$ is rotated about the

a) x -axis



$R = \underline{\hspace{2cm}}$ $r = \underline{\hspace{2cm}}$

$V = \underline{\hspace{2cm}}$

b) the line $y = 4$



$R = \underline{\hspace{2cm}}$ $r = \underline{\hspace{2cm}}$

$V = \underline{\hspace{2cm}}$

c) the line $y = 5$



$R = \underline{\hspace{2cm}}$ $r = \underline{\hspace{2cm}}$

$V = \underline{\hspace{2cm}}$

d) the y -axis

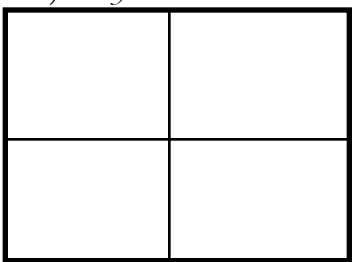

$R = \underline{\hspace{2cm}}$ $r = \underline{\hspace{2cm}}$

$V = \underline{\hspace{2cm}}$

e) the line $x = 2$

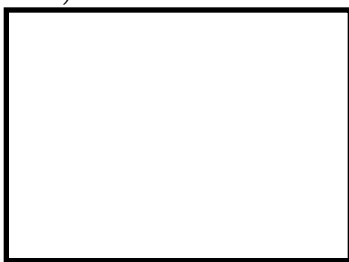

$R = \underline{\hspace{2cm}}$ $r = \underline{\hspace{2cm}}$

$V = \underline{\hspace{2cm}}$

f) the line $x = 4$

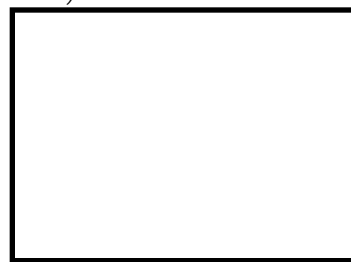

$R = \underline{\hspace{2cm}}$ $r = \underline{\hspace{2cm}}$

$V = \underline{\hspace{2cm}}$

Example 4) Find the volume if the region enclosing $y = 1 + \sqrt{x}, y = 1, x = 4$ is rotated about the

a) x -axis



$R = \underline{\hspace{2cm}}$ $r = \underline{\hspace{2cm}}$

$V = \underline{\hspace{2cm}}$

b) the line $y = 3$



$R = \underline{\hspace{2cm}}$ $r = \underline{\hspace{2cm}}$

$V = \underline{\hspace{2cm}}$

c) the line $y = 5$



$R = \underline{\hspace{2cm}}$ $r = \underline{\hspace{2cm}}$

$V = \underline{\hspace{2cm}}$

d) the y -axis

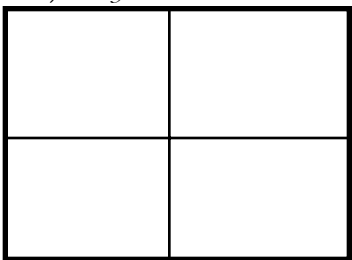

$R = \underline{\hspace{2cm}}$ $r = \underline{\hspace{2cm}}$

$V = \underline{\hspace{2cm}}$

e) the line $x = 4$

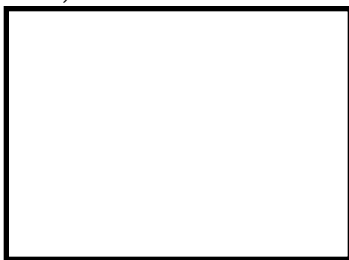

$R = \underline{\hspace{2cm}}$ $r = \underline{\hspace{2cm}}$

$V = \underline{\hspace{2cm}}$

f) the line $x = 6$

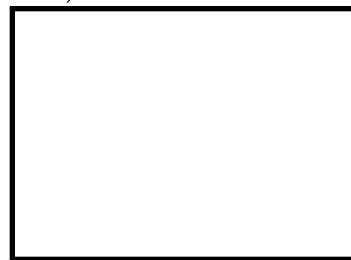

$R = \underline{\hspace{2cm}}$ $r = \underline{\hspace{2cm}}$

$V = \underline{\hspace{2cm}}$

Example 5) Find the volume if the region enclosing $y = x + 1, x = 0, y = 0, x = 3$ is rotated about the

a) x -axis



$R = \underline{\hspace{2cm}}$ $r = \underline{\hspace{2cm}}$

$V = \underline{\hspace{2cm}}$

b) the y -axis



$R = \underline{\hspace{2cm}}$ $r = \underline{\hspace{2cm}}$

$V = \underline{\hspace{2cm}}$

c) the line $x = 3$



$R = \underline{\hspace{2cm}}$ $r = \underline{\hspace{2cm}}$

$V = \underline{\hspace{2cm}}$

Example 6) Find the volume if the region enclosing $y = x^2, y = \sqrt[3]{x}$ is rotated about the

a) x -axis



$R = \underline{\hspace{2cm}}$ $r = \underline{\hspace{2cm}}$

$V = \underline{\hspace{2cm}}$

b) the y -axis



$R = \underline{\hspace{2cm}}$ $r = \underline{\hspace{2cm}}$

$V = \underline{\hspace{2cm}}$

c) the line $y = 1$



$R = \underline{\hspace{2cm}}$ $r = \underline{\hspace{2cm}}$

$V = \underline{\hspace{2cm}}$

Example 7) The region in the figure below is revolved about the indicated lines. Order the volumes of the resulting solids from smallest to largest. Justify your answers. a) x -axis b) y -axis c) $x = 4$, d) $y = 2$

The function is bordered by $y = \sqrt{x}, y = 0, x = 4$

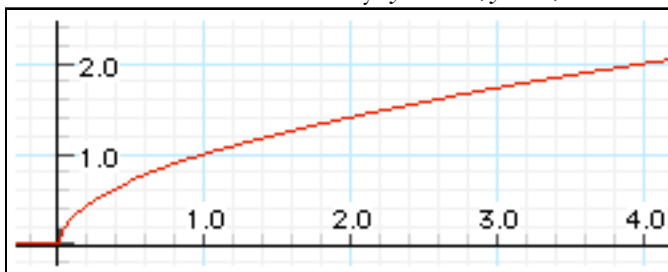

Example 8) Find the volume of the solid whose base is bounded by the circle $x^2 + y^2 = 25$ with the indicated cross sections taken perpendicular to the x -axis

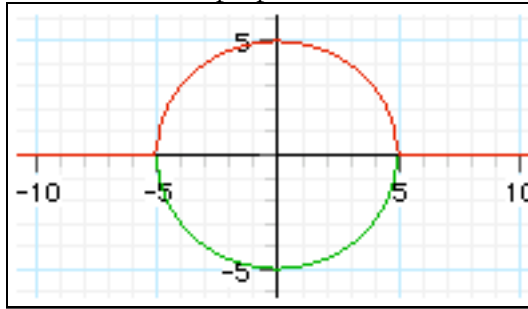

- a) squares
 b) equilateral triangles
 c) semi-circles
 d) isosceles right triangles

Example 9) Find the volume of the solid whose base is bounded by the lines $y = x - 4$, $y = 4 - x$ and $x = 0$ with the indicated cross sections taken perpendicular to the x -axis

- a) squares
 b) equilateral triangles
 c) semi circles
 d) isosceles right triangles

Example 10) A horn for a public address system is to be made with the inside cross sections increasing exponentially with distance from the speaker. The horn will have the shape of the solid formed when the region bounded by $y = e^{0.4x}$ and $y = x + 1$ from $x = 0$ to $x = 3$ is rotated about the x -axis. If x and y are in feet, find the volume of the material used to make this speaker. (Calculator solution allowed).

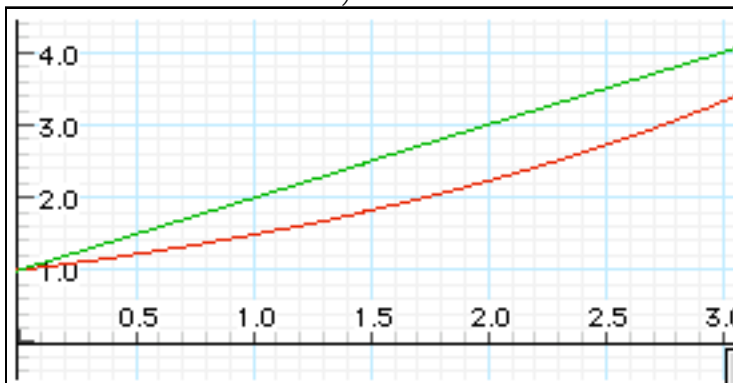

Volume by Disks/Washers - Homework

1. Find the volume if the region enclosing $y = 4 - x, x = 0, y = 0$ is rotated about the

a) x -axis



$R = \underline{\hspace{2cm}}$ $r = \underline{\hspace{2cm}}$

$V = \underline{\hspace{4cm}}$

b) the line $y = 4$



$R = \underline{\hspace{2cm}}$ $r = \underline{\hspace{2cm}}$

$V = \underline{\hspace{4cm}}$

c) the line $y = 5$

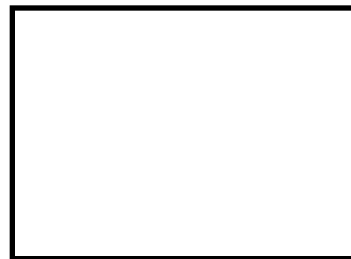

$R = \underline{\hspace{2cm}}$ $r = \underline{\hspace{2cm}}$

$V = \underline{\hspace{4cm}}$

d) the y -axis

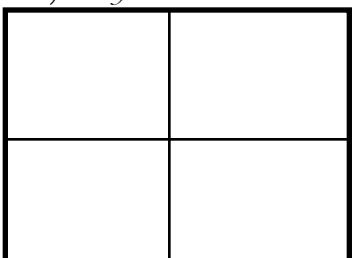

$R = \underline{\hspace{2cm}}$ $r = \underline{\hspace{2cm}}$

$V = \underline{\hspace{4cm}}$

e) the line $x = 4$

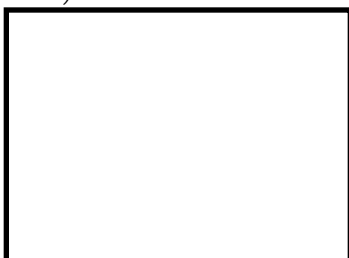

$R = \underline{\hspace{2cm}}$ $r = \underline{\hspace{2cm}}$

$V = \underline{\hspace{4cm}}$

f) the line $x = 6$



$R = \underline{\hspace{2cm}}$ $r = \underline{\hspace{2cm}}$

$V = \underline{\hspace{4cm}}$

2. Find the volume if the region enclosing $y = x^2 + x, y = 0, x = 2$ is rotated about the

a) x -axis



$R = \underline{\hspace{2cm}}$ $r = \underline{\hspace{2cm}}$

$V = \underline{\hspace{4cm}}$

b) the line $y = 6$



$R = \underline{\hspace{2cm}}$ $r = \underline{\hspace{2cm}}$

$V = \underline{\hspace{4cm}}$

c) the line $y = 9$



$R = \underline{\hspace{2cm}}$ $r = \underline{\hspace{2cm}}$

$V = \underline{\hspace{4cm}}$

3. Find the volume if the region enclosing $y = x^3, x = 0, y = 8$ is rotated about the

a) x -axis

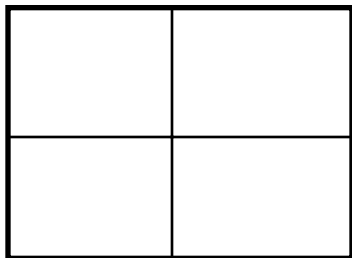

$R = \underline{\hspace{2cm}}$ $r = \underline{\hspace{2cm}}$

$V = \underline{\hspace{2cm}}$

b) the line $y = 8$



$R = \underline{\hspace{2cm}}$ $r = \underline{\hspace{2cm}}$

$V = \underline{\hspace{2cm}}$

c) the line $y = 9$



$R = \underline{\hspace{2cm}}$ $r = \underline{\hspace{2cm}}$

$V = \underline{\hspace{2cm}}$

d) the y -axis

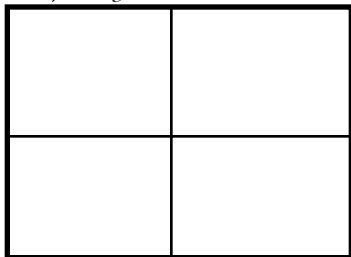

$R = \underline{\hspace{2cm}}$ $r = \underline{\hspace{2cm}}$

$V = \underline{\hspace{2cm}}$

e) the line $x = 2$



$R = \underline{\hspace{2cm}}$ $r = \underline{\hspace{2cm}}$

$V = \underline{\hspace{2cm}}$

f) the line $x = 3$



$R = \underline{\hspace{2cm}}$ $r = \underline{\hspace{2cm}}$

$V = \underline{\hspace{2cm}}$

4. Find the volume if the region enclosing $y = x^2, y = 2x, x \geq 0$ is rotated about the

a) x -axis

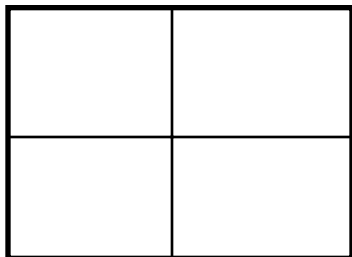

$R = \underline{\hspace{2cm}}$ $r = \underline{\hspace{2cm}}$

$V = \underline{\hspace{2cm}}$

b) the line $y = 4$

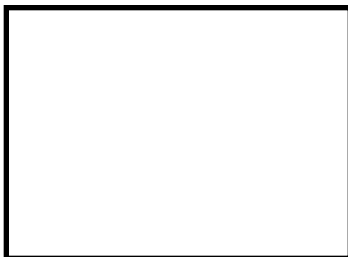

$R = \underline{\hspace{2cm}}$ $r = \underline{\hspace{2cm}}$

$V = \underline{\hspace{2cm}}$

c) the line $y = 7$

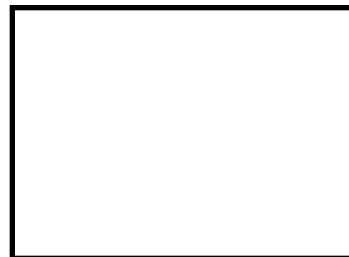

$R = \underline{\hspace{2cm}}$ $r = \underline{\hspace{2cm}}$

$V = \underline{\hspace{2cm}}$

d) the y -axis

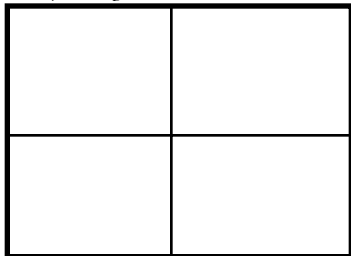

$R = \underline{\hspace{2cm}}$ $r = \underline{\hspace{2cm}}$

$V = \underline{\hspace{2cm}}$

e) the line $x = 2$



$R = \underline{\hspace{2cm}}$ $r = \underline{\hspace{2cm}}$

$V = \underline{\hspace{2cm}}$

f) the line $x = 3$

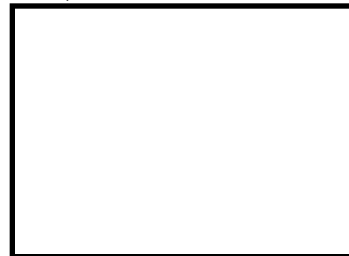

$R = \underline{\hspace{2cm}}$ $r = \underline{\hspace{2cm}}$

$V = \underline{\hspace{2cm}}$

5. Find the volume if the region enclosing $y = 1 + \sqrt{x}$, $x = 0$, $y = 0$, $x = 9$ is rotated about the

a) x -axis



$R = \underline{\hspace{2cm}}$ $r = \underline{\hspace{2cm}}$

$V = \underline{\hspace{2cm}}$

b) the line $y = 4$



$R = \underline{\hspace{2cm}}$ $r = \underline{\hspace{2cm}}$

$V = \underline{\hspace{2cm}}$

c) the line $y = 5$



$R = \underline{\hspace{2cm}}$ $r = \underline{\hspace{2cm}}$

$V = \underline{\hspace{2cm}}$

d) the y -axis

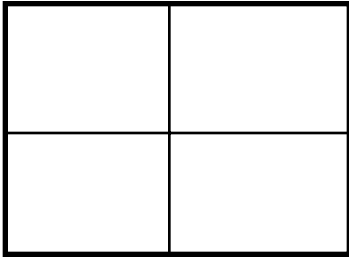

$R = \underline{\hspace{2cm}}$ $r = \underline{\hspace{2cm}}$

$V = \underline{\hspace{2cm}}$

e) the line $x = 9$



$R = \underline{\hspace{2cm}}$ $r = \underline{\hspace{2cm}}$

$V = \underline{\hspace{2cm}}$

6. Find the volume if the first quadrant region $y = \sin x$ and $y = \cos x$ on $[0, \pi/4]$ is rotated about

a) x -axis

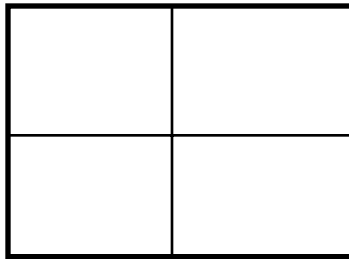

$R = \underline{\hspace{2cm}}$ $r = \underline{\hspace{2cm}}$

$V = \underline{\hspace{2cm}}$

b) the y -axis

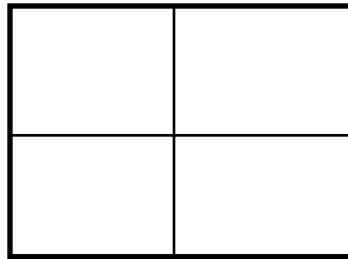

$R = \underline{\hspace{2cm}}$ $r = \underline{\hspace{2cm}}$

$V = \underline{\hspace{2cm}}$

7. A tank on the wing of a jet plane is formed by revolving the region bounded by the graph of $y = \frac{1}{10}x^2\sqrt{3-x}$ and the x -axis about the x -axis where x and y are measured in meters. Find the volume of the tank.

8. The region bounded by the curve $y = \sqrt{x}$, $x = 0$, $y = 0$, $x = 9$ is rotated about the x -axis.

a) Find the value of a in the interval $[0, 9]$ that divides the region into 2 parts of equal area.

b) Find the value of a in the interval $[0, 9]$ that divides the solid into 2 parts of equal volume.

9. Find the volume of the solid whose base is bounded by the circle whose center is the origin and whose radius is 10 with the indicated cross sections perpendicular to the x -axis

a) squares

b) equilateral triangles

c) semi-circles

d) isosceles right triangles

10. Find the volume of the solid whose base is bounded by the curves $y = x^2 - x - 3$ and $y = x$ with the indicated cross sections taken perpendicular to the x -axis

a) squares

b) equilateral triangles

c) semi-circles

d) isosceles right triangles

Volume by Cylindrical Shells - Classwork

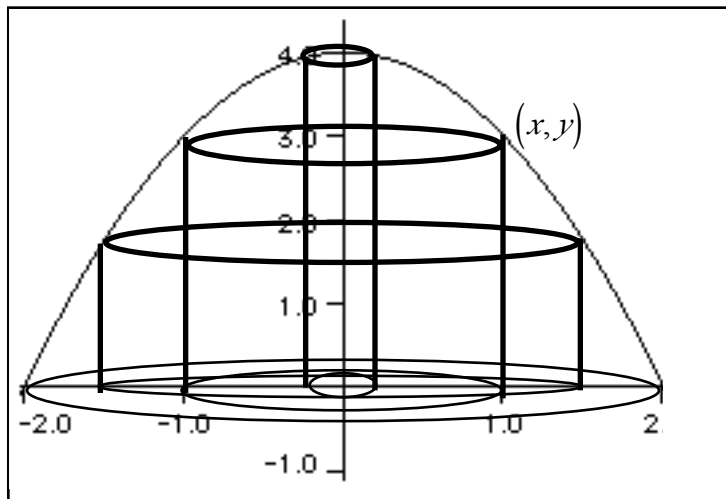

There is another way to determine the volume of a curve that is rotated about an axis - the method of cylindrical shells. Let us take some function $y = f(x)$ and rotate it about the y -axis as shown above. Instead of creating a disk, we will create a cylinder. This cylinder is very thin - its sides are like paper. We call it a cylindrical shell. We can draw many such cylinders (above three are drawn). Note that they all have different heights and different radii.

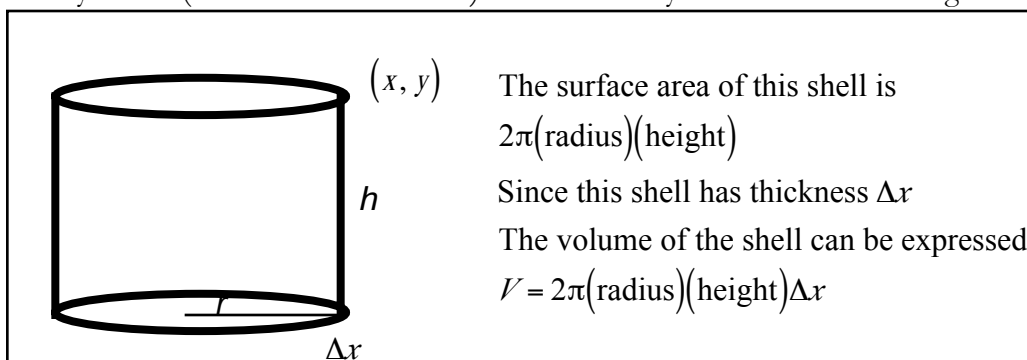

Since we are using infinitely thin shells $\left(\lim_{\Delta x \rightarrow 0}\right)$, we can say that the volume of our rotated region is

$$V = \lim_{n \rightarrow \infty} \left[\sum_{i=1}^n 2\pi \cdot (\text{radius}_i)(\text{height}_i)\Delta x \right]$$

$$\int_{x=a}^{x=b} 2\pi r \cdot h \, dx \text{ if rotated about } y\text{-axis or vertical line}$$

$$\int_{y=a}^{y=b} 2\pi r \cdot h \, dy \text{ if rotated about } x\text{-axis or horizontal line}$$

So when you attempt a problem by cylindrical shells, your job is to determine both the radius and height. Note that in using the disk/washer method, it is usually better to rotate about the x -axis or lines parallel to the x -axis ($y = \text{constant}$) because the outside and inside radii are expressed as a vertical distance which will be a function of x . The shell method's advantage is usually in rotating about the y -axis or lines parallel to the y -axis ($x = \text{constant}$) because the radius is a horizontal distance given some function of x and the height is the vertical distance which is a function of x . So from now on, it is recommended that you use shells when rotating around the y -axis or lines parallel to the y -axis.

1. Find the volume if the region enclosing $y = 2x, y = 0, x = 3$ is rotated about the

a) the y -axis



$r = \underline{\hspace{2cm}}$ $h = \underline{\hspace{2cm}}$
 $V = \underline{\hspace{4cm}}$

b) the line $x = 3$



$r = \underline{\hspace{2cm}}$ $h = \underline{\hspace{2cm}}$
 $V = \underline{\hspace{4cm}}$

c) the line $x = 4$



$r = \underline{\hspace{2cm}}$ $h = \underline{\hspace{2cm}}$
 $V = \underline{\hspace{4cm}}$

d) x -axis

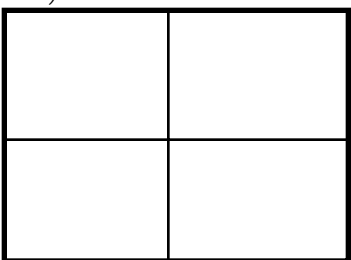

$R = \underline{\hspace{2cm}}$ $h = \underline{\hspace{2cm}}$
 $V = \underline{\hspace{4cm}}$

e) the line $y = 6$

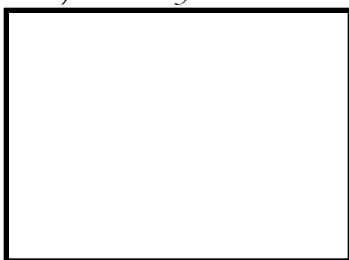

$R = \underline{\hspace{2cm}}$ $h = \underline{\hspace{2cm}}$
 $V = \underline{\hspace{4cm}}$

f) the line $y = 8$

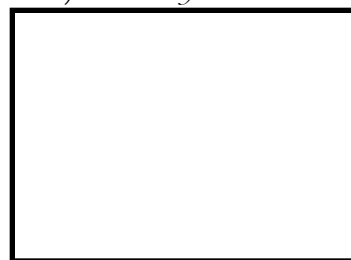

$R = \underline{\hspace{2cm}}$ $h = \underline{\hspace{2cm}}$
 $V = \underline{\hspace{4cm}}$

Again, the shell method's greatest advantage is rotating around the y -axis when the problem can be in terms of x . A downside of the shell method is that you may not be able to integrate using the Fundamental Theorem. Calculators are of a real advantage here.

2. Find the volume if the region enclosing $y = x^2, y = 0, x = 4$ is rotated about the

a) y -axis



$r = \underline{\hspace{2cm}}$ $h = \underline{\hspace{2cm}}$
 $V = \underline{\hspace{4cm}}$

b) the line $x = 4$



$r = \underline{\hspace{2cm}}$ $h = \underline{\hspace{2cm}}$
 $V = \underline{\hspace{4cm}}$

3. Find the volume if the region enclosing $y = x^3, y = 8, x = 0$ is rotated about the

a) y -axis



$r = \underline{\hspace{2cm}}$ $h = \underline{\hspace{2cm}}$
 $V = \underline{\hspace{4cm}}$

Volume by Cylindrical Shells - Homework

1. Find the volume if the region enclosing $y = -x^2 + 4x + 3, x = 0, x = 4, y = 0$ is rotated about

a) y -axis

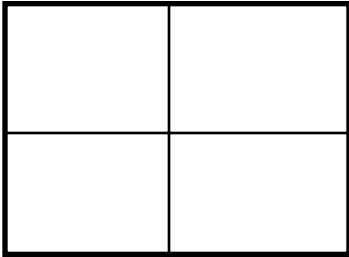

$r = \underline{\hspace{2cm}}$ $h = \underline{\hspace{2cm}}$
 $V = \underline{\hspace{4cm}}$

b) the line $x = 4$



$r = \underline{\hspace{2cm}}$ $h = \underline{\hspace{2cm}}$
 $V = \underline{\hspace{4cm}}$

c) the line $x = 5$



$r = \underline{\hspace{2cm}}$ $h = \underline{\hspace{2cm}}$
 $V = \underline{\hspace{4cm}}$

2. Find the volume if the first quadrant region enclosing $y = x^2, y = 8 - x^2$ is rotated about

a) y -axis



$r = \underline{\hspace{2cm}}$ $h = \underline{\hspace{2cm}}$
 $V = \underline{\hspace{4cm}}$

b) the line $x = 2$



$r = \underline{\hspace{2cm}}$ $h = \underline{\hspace{2cm}}$
 $V = \underline{\hspace{4cm}}$

c) the line $x = -1$



$r = \underline{\hspace{2cm}}$ $h = \underline{\hspace{2cm}}$
 $V = \underline{\hspace{4cm}}$

3. Find the volume if the region enclosed by $y = \sin x, y = 0$ on $[0, \pi]$ is rotated about

a) y -axis

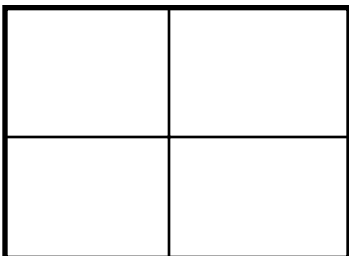

$r = \underline{\hspace{2cm}}$ $h = \underline{\hspace{2cm}}$
 $V = \underline{\hspace{4cm}}$

b) the line $x = \pi$

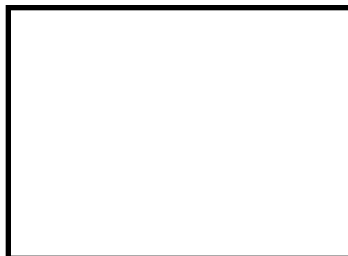

$r = \underline{\hspace{2cm}}$ $h = \underline{\hspace{2cm}}$
 $V = \underline{\hspace{4cm}}$

c) the line $x = 2\pi$

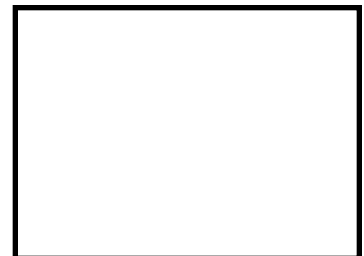

$r = \underline{\hspace{2cm}}$ $h = \underline{\hspace{2cm}}$
 $V = \underline{\hspace{4cm}}$

Review of Exponentials and Logarithms - Classwork

In our study of calculus, we have examined derivatives and integrals of polynomial expressions, rational expressions, and trigonometric expressions. What we have not examined are exponential expressions, expressions of the form $y = a^x$. While these are covered extensively in precalculus, a little review is in order and these types of expressions are very prevalent in the calculus theatre.

An expressions in the form of $y = a^x$ will graph an exponential. An exponential graph tends to “explode” based on the value of x , since the x is in the exponent.

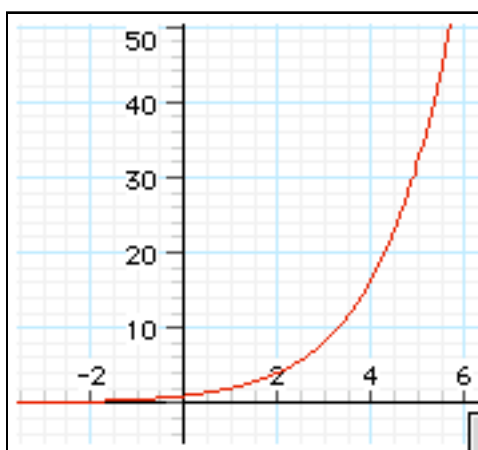

$$y = 2^x$$

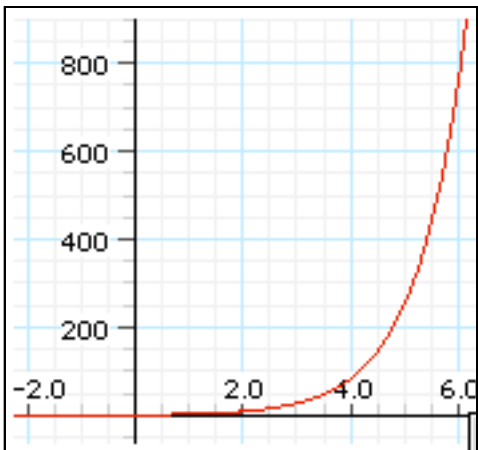

$$y = 3^x$$

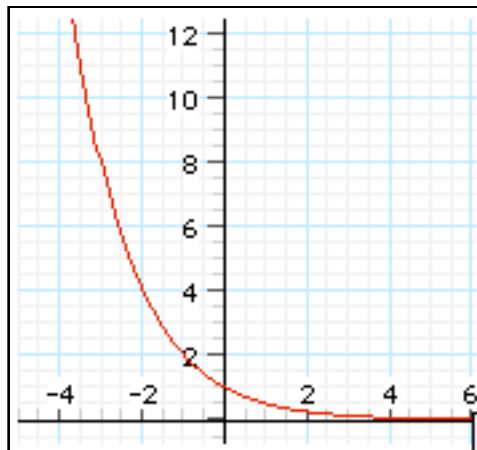

$$y = .5^x$$

The graph of various exponential curves are shown above. We know that the graph of $y = 1^x$ graphs _____.

If $a < 0$, the graph of $y = a^x$ will not exist at certain points for instance, what is $(-2)^{1/2}$? _____

So it only makes sense to examine functions in form of $y = a^x$, if $a > 0$, $a \neq 1$. When $a > 1$, we get what is called a growth curve and the larger a is, the steeper the growth curve is. If $0 < a < 1$, the we get a decay curve as shown in the 3rd graph above. No matter what, exponential curves in the form of $y = a^x$ have certain features.

What point do they have in common? _____ What is the domain? _____ What is the range? _____

Solving basic exponential equations can be accomplished by using the fact that if $a^x = a^y$, then $x = y$.

Examples) Solve for x .

1) $2^{x+1} = 8$

2) $3^{2x-3} = \frac{1}{3}$

3) $4^{5x-1} = \sqrt[3]{32}$

4) $7^{2x+3} = \left(\frac{1}{49}\right)^{3-x}$

5) $8^{5-2x} = 1$

Solving exponential equations like the ones above are easy when each side of the equation have common bases. But problems like $3^{x-1} = 4$ cause problems. With that problem created, we introduced the concept of logarithms. A logarithm is simply an inverse of an exponential. Students typically hear the word logarithm and go into a cold sweat because they do not understand them. So lets get it straight once and for all.

The statement $y = b^x$ can be written in an alternate way: $x = \log_b y$. They mean the same thing.

Whenever you are given a logarithmic statement, write it exponentially. You will know the answer!

Examples: find the value of the following:

- 1) $\log_2 8$ 2) $\log_5 \frac{1}{25}$ 3) $\log_8 \sqrt{2}$ 4) $5 \log_6 1$ 5) $\log_7 0$

If the base is not specified, it is assumed to be 10. $\log_{10} x$ and $\log x$ are the same things.

Examples) Find the value of the following:

- 6) $\log 100$ 7) $\log 1$ 8) $5 \log \sqrt{10}$ 9) $\log \frac{1}{1000}$ 10) $\log 10^{\sqrt{5}}$

On what seems to be a side note, let's examine the expression $y = \left(1 + \frac{1}{x}\right)^x$ for various values of x . What we are doing is looking at $\left(1 + \frac{1}{1}\right)^1, \left(1 + \frac{1}{2}\right)^2, \left(1 + \frac{1}{3}\right)^3, \left(1 + \frac{1}{4}\right)^4 \dots \left(1 + \frac{1}{50}\right)^{50} \dots$. Logic would tell us that as x gets larger, $1 + \frac{1}{x}$ gets _____ and this the limit as x approaches infinity of $1 + \frac{1}{x}$ is _____. Thus, logic also dictates that $\lim_{x \rightarrow \infty} \left(1 + \frac{1}{x}\right)^x = \underline{\hspace{2cm}}$. But when you play with infinity, logic doesn't always work. You can see that if you set up your calculator with the expression $Y1 = \left(1 + \frac{1}{x}\right)^x$ and look at a table of values.

x	$\left(1 + \frac{1}{x}\right)^x$	x	$\left(1 + \frac{1}{x}\right)^x$	x	$\left(1 + \frac{1}{x}\right)^x$	x	$\left(1 + \frac{1}{x}\right)^x$
1	2	100	2.70481383	1000	2.71692393	100000	2.71826824
2	2.25	110	2.70602808	2000	2.71760257	200000	2.71827503
3	2.37037037	120	2.70704149	3000	2.71782892	300000	2.7182773
4	2.44140625	130	2.70790008	4000	2.71794212	400000	2.71827843
5	2.48832	140	2.70863681	5000	2.71801005	500000	2.71827911
6	2.52162637	150	2.70927591	6000	2.71805534	600000	2.71827956
7	2.5464997	160	2.70983558	7000	2.71808769	700000	2.71827989
8	2.56578451	170	2.71032975	8000	2.71811196	800000	2.71828013
9	2.58117479	180	2.7107693	9000	2.71813083	900000	2.71828032
10	2.59374246	190	2.71116279	10000	2.71814593	1000000	2.71828047

If should be obvious that as x gets larger and larger, the expression $\left(1 + \frac{1}{x}\right)^x$ is not approaching one but the number _____ . This number is a very special number in mathematics and is called Euler's number. Leonhard Euler (1707 - 1783) discovered this number and it is known as e . The value of e is 2.718281828.... e is a number which, like π and $\sqrt{2}$, continues on forever without any pattern. (Note: the 1828 in e , although appearing twice consecutively near the start does not appear again for a very long while. It is completely coincidental that it appears twice)

The number e is such an important number (if you would have to decide what the 5 most important numbers are, what would they be? _____, _____, _____, _____, _____), that it forms the basic of what are called natural logarithms of Napierian logs (after John Napier, 1550-1617, who first used them). Just as logarithms (log) use base 10, natural logs (ln) use base e . When you wish to find the value of a log, you write the expression exponentially. You do the same thing with a natural log except that your base is now e .

For instance, to find $\ln 10$, you call it x , and are now solving the equation $e^x = 10$. Since e is slightly below 3, we expect $\ln 10$ to be between the values of _____ and _____.

So, given the function $y = e^x$, the domain is _____ and the range is _____.

Examples) Find the value of the following:

11) $\ln e^4$

12) $9 \ln 1$

13) $8 \ln \sqrt{e}$

14) $\ln \frac{1}{e^3}$

15) $e^{\ln 5}$

There are three basic rules for operation with logarithms that you must know. They are as follows:

1. $\log(a \cdot b) = \log a + \log b$	2. $\log\left(\frac{a}{b}\right) = \log a - \log b$	3. $\log a^b = b \log a$
--	---	--------------------------

These rules work with logs to any base of the ln function.

Examples) Find the value of the following expressions:

16) $\log 25 + \log 4$

17) $\log_2 40 - \log_2 5$

18) $\log 10^{35}$

19) $\log_4 x + \log_4 (x + 12) = 3$ - solve for x

Review of Exponentials and Logarithms - Homework

For each curve below, identify it by the proper equation letter. No calculators.

a. $y = 2^x$

d. $y = -3^x$

g. $y = 4^x - 2$

j. $y = 3^{x+1}$

m. $y = 2^{x/2}$

b. $y = 2^{-x}$

e. $y = -3(2^x)$

h. $y = .5^x - 3$

k. $y = 2^{x-1} + 2$

n. $y = 1.1^x$

c. $y = 2(2^x)$

f. $y = .5(4^x)$

i. $y = -2(.5^x) + 1$

l. $y = .5^{x-2}$

o. $y = 4^x + 4^{-x}$

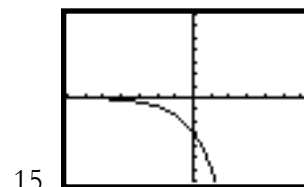
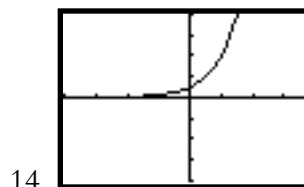
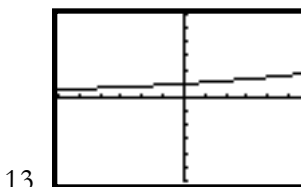
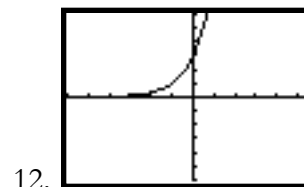
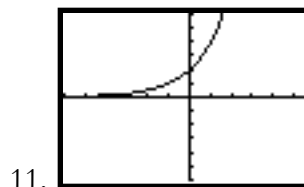
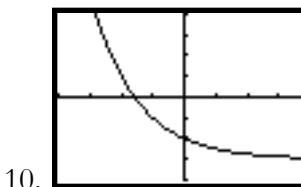
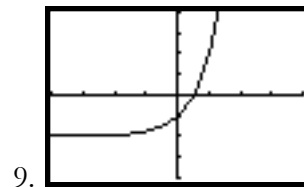
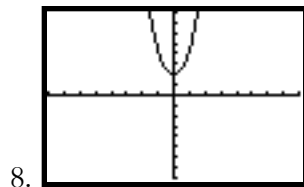
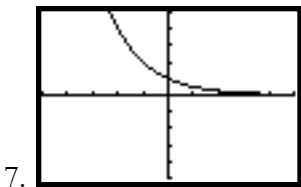
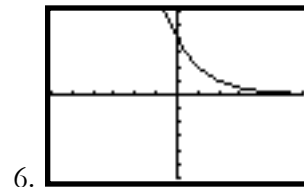
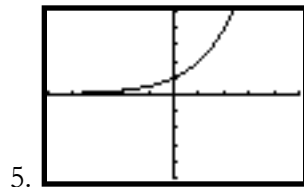
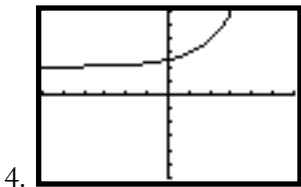
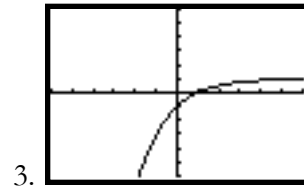
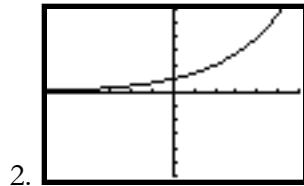
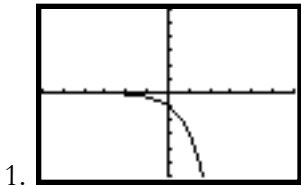

Solve for x

16. $2^{x-3} = 16$

17. $3^{2x-3} = 81$

18. $5^{3x-3} = 1$

19. $2^{5-2x} = \frac{1}{2}$

20. $10^{5x+6} = \frac{1}{100}$

21. $2^{4x+1} = \sqrt{2}$

22. $27^{3x+3} = 9$

23. $16^{x-3} = 8^{x-3}$

24. $25^{6-2x} = \sqrt{5}$

25. $9^{2x-4} = \left(\frac{1}{27}\right)^{x-3}$

26. $\left(\frac{1}{32}\right)^{x+6} = \left(\frac{1}{8}\right)^{x-2}$

27. $\left(\frac{1}{4}\right)^{2-2x} = \left(\sqrt[3]{2}\right)^{3x+6}$

28. $\log_4 256$

29. $\log_2 8$

30. $\log_8 2$

31. $\log_5 125$

32. $\log_9 27$

33. $\log_7 1$

34. $\log_{25} 5$

35. $\log_8 16$

36. $\log_{\sqrt{3}} 27$

37. $\log_{\frac{1}{5}} \frac{1}{125}$

38. $-5\log_{12} 12$

39. $10^{\log 29}$

40. $\ln e^4$

41. $e^{\ln \sqrt{e}}$

42. $\frac{3\log 10}{2\ln e}$

Solve each equation in terms of x .

43. $\log_3(2x - 2) = 2$

44. $\log_7(7x - 6) = 2$

45. $\ln 3x + \ln 3 = 3$

46. $\log_5(x + 3) - \log_5 x = 2$

If $a = \log_2 6$ and $b = \log_2 10$, express the following in terms of a and b .

47. $\log_2 24$

48. $\log_2 600$

49. $\log_2 \sqrt[4]{10}$

Differentiation of the Natural Log Function - Classwork

We have examined derivatives using the power rule, product rule, quotient rule, and trig. But what about the derivative of $y = \ln x$? We have no rule to cover such functions. Let's see how your calculator deals with it. In your TI-84 calculator, let $Y1 = nDerviv(\ln x, x, x)$ and set up your table with x starting at 1 and $\Delta x = 1$.

x	0	1	2	3	4	5	6	7	8	9	10
y'	ERROR	1.000	0.500	0.333	0.250	0.200	0.167	0.143	0.125	0.111	0.100

As you look at the relationship between the value of x and the value of the derivative of $\ln x$, it should be clear. What is it? _____

So we have a new differentiation rule - the ln rule:

$$\frac{d}{dx}[\ln x] = \frac{1}{x}, x > 0$$

$$\frac{d}{dx}[\ln u] = \frac{1}{u} \cdot \frac{du}{dx} = \frac{u'}{u}, u > 0$$

$$\frac{d}{dx}[\ln|u|] = \frac{1}{u} \cdot \frac{du}{dx} = \frac{u'}{u}, u \neq 0$$

What this says is to take the derivative of the ln of some expressions, you simply use the reciprocal of the expression multiplied by the derivative of that expression. The expression must be a positive number.

Examples) Find the derivative of the following expressions:

1) $y = \ln(4x)$

2) $y = \ln(x^2 - 3)$

3) $y = \ln(3x^2 - 5x + 8)$

4) $y = \ln\sqrt{x}$

You now have 5 sets of rules - power, product, quotient, trig (6 rules), and now "ln". Just because there is an "ln" in the problem does not mean it uses the ln rule above.

Examples) Find the derivative of the following expressions:

5) $y = x^2 \ln x$

6) $y = \frac{\ln x}{x}$

7) $y = \frac{x}{\ln x}$

8) $y = (\ln x)^5$

9) $y = \sqrt{\ln x}$

10) $y = \cos(\ln x)$

11) $y = \ln(\cos x)$

12) $y = \ln(\ln x)$

Remember your log rules. They can help you to take derivative of harder expressions.

1. $\log(a \cdot b) = \log a + \log b$	2. $\log\left(\frac{a}{b}\right) = \log a - \log b$	3. $\log a^b = b \log a$
--	---	--------------------------

Examples) Find the derivative dy/dx of the following expressions:

13) $y = \ln\sqrt{x^2 + 2x - 3}$

Hard way:

14) $y = \ln\frac{x^2}{3x-2}$

Easy way:

15) $y = \ln(x\sqrt{3x-1})$

16) $y = \ln\sqrt{\frac{x^2+1}{x^2-1}}$

17) $y = \ln\frac{x(x^2+3)^3}{\sqrt[3]{2x^2+4}}$

18) $x^2 - 3\ln y + y^2 = 25$

19) Find relative extrema of
 $y = \ln(x^2 + 4x + 6)$

20) Find the equation of the tangent
line to $y = 4x^2 - \ln x$ at $(1,4)$

A technique not included on the AP exam but helpful to taking hard derivatives is called logarithmic differentiation. It essentially says to take the natural log of the hard expression in order to take advantage of the

log rules. Example 21) $y = \frac{(2x-1)^3}{\sqrt{x^2+x+1}}$

Differentiation of the Natural Log Function - Homework

Find the derivative dy/dx of the following expressions:

1. $y = \ln x^6$

2. $y = \ln(x^2 - 5x - 2)$

3. $y = (\ln x)^7$

4. $y = x^3 \ln x$

5. $y = \frac{x^4}{\ln x}$

6. $y = \frac{\ln x}{x^4}$

7. $y = x^2 - 4 \ln x - 2$

8. $y = \ln(\ln 3x^2)$

9. $y = \ln \sin x$

10. $y = \sin(\ln x)$

11. $y = x \ln \tan x$

12. $y = \frac{\tan x}{\ln x}$

13. $y = \ln[(3x^2 - 3x + 2)(5x - 1)]$

14. $y = \ln \frac{3x^2 - 3x + 2}{5x - 1}$

15. $y = \ln \sqrt{x^2 - 4x - 7}$

16. $y = \ln \sqrt[5]{3x^3 - 2x^2 + 5x - 1}$

17. $y = \ln \sqrt{\frac{2x - 1}{2x + 1}}$

18. $y = \ln \left[x \cdot \sqrt[3]{\frac{2x - 1}{2x + 1}} \right]$

Use implicit differentiation to find dy/dx .

19. $4x^2 + 2\ln y + y^3 = 12$

20. $\ln xy - 3x = 4$

21. $\frac{\ln y}{x} = x + y$

Find the equation of the line tangent to the graph of the following functions at the indicated point.

22. $y = -2x^2 + \ln x - 1$ at $(1, -3)$

23. $y = 6 - x^2 - \ln(2x + 1)$ at $(0, 6)$

24. $y = x^3 - \ln \frac{x}{e}$ at $(1, 2)$

Find any relative extrema to the following functions.

25. $y = \frac{x^2}{4} - \ln x$

26. $y = \ln x - x$

27. $y = 2x^2 \ln x$

28. $y = \frac{\ln x}{2x}$

Use logarithmic differentiation to find dy/dx .

29. $y = \sqrt{(x-3)(x-4)(x-5)}$

30. $y = \sqrt{\frac{x^2-2}{x^2+2}}$

the Natural Log Function and Integration - Classwork

The derivative rules which we just learned will now produce the following integration rules:

$$\int \frac{1}{x} dx = \ln|x| + C \quad \text{and if } u \text{ is a differentiable function of } x, \int \frac{1}{u} du = \ln|u| + C$$

Examples) Find the following:

1) $\int \frac{4}{x} dx$

2) $\int \frac{1}{5x-2} dx$

3) $\int \frac{4}{3-6x} dx$

4) $\int \frac{7x}{x^2-4} dx$

When you take integrals of fractions, you usually think u -substitution with the u being the denominator generating a \ln function. But not always.

5) $\int \frac{x}{\sqrt{16-x^2}} dx$

6) $\int \frac{1}{\sqrt[3]{2x-1}} dx$

7) $\int \frac{(\ln x)^4}{x} dx$

8) $\int \frac{x^2-2x+1}{x} dx$

9) $\int \tan x dx$

10) $\int \cot 3x dx$

11) $\int \frac{\cos x}{2 + \sin x} dx$

12) $\int \frac{1}{\cos^2 x \tan x} dx$

13) $\int_0^4 \frac{4}{2x+1} dx$

14) $\int_e^{e^2} \frac{1}{x \ln x} dx$

15) $\int_0^{\pi/2} \frac{\sin x}{1 + \cos x} dx$

the Natural Log Function and Integration - Homework

Find the following:

$$1. \int \frac{2}{x+2} dx$$

$$2. \int \frac{5}{4-3x} dx$$

$$3. \int \frac{x}{x^2-1} dx$$

$$4. \int \frac{x^2}{5-x^3} dx$$

$$5. \int \frac{x}{\sqrt[3]{x^2+1}} dx$$

$$6. \int \frac{x^2-3x-5}{x} dx$$

$$7. \int \frac{2x-5}{x^2-5x-1} dx$$

$$8. \int \frac{x+4}{x^2+8x-3} dx$$

$$9. \int \frac{(\ln x)^5}{x} dx$$

$$10. \int \frac{5}{x \ln x} dx$$

$$11. \int \tan 4\theta d\theta$$

$$12. \int \frac{\sin \theta}{4-3\cos \theta} d\theta$$

$$13. \int_0^4 \frac{4}{2x+1} dx$$

$$14. \int_1^e \frac{(1+\ln x)^3}{x} dx$$

$$15. \int_0^{\pi/2} \frac{1-\sin x}{x+\cos x} dx$$

Derivatives and Integrals of Expressions with “e” - Classwork

Let us try to take the derivative of $y = e^x$. Again, it seems as if that there is no rule (power, product, quotient, trig, ln) to take it. Let's examine this by use of the calculator. Set $Y1 = e^x$ and $Y2 = \text{NDeriv}(e^x, x, x)$. Then set a table to look at these values.

x	-4	-3	-2	-1	0	1	2	3	4
e^x	0.018	0.050	0.135	0.368	1.000	2.718	7.389	20.086	54.598
$\frac{d}{dx}(e^x)$	0.018	0.050	0.135	0.368	1.000	2.718	7.389	20.086	54.598

It should be obvious (and surprising) what is happening. Let's try and prove it. Let's take the derivative of $y = e^x$ using logarithmic differentiation.

So we end up with the result that equations in the form of $y = Ce^x$ are the only equations (with the exception of $y = 0$) whose derivative is the same as the expression itself.

$$\frac{d}{dx}[e^x] = e^x \text{ and if } u \text{ is a differentiable function of } x \text{ then } \frac{d}{dx}[e^u] = e^u \frac{du}{dx}$$

Examples) Find the derivative dy/dx of the following expressions:

1) $y = e^{5x}$ 2) $y = 4e^{1-2x}$ 3) $y = e^{x^2-3x-1}$ 4) $y = 2e^{\sqrt{x}}$

We now have 6 basic rules for derivatives: power, product, quotient, trig (6), ln, and now e .

5) $y = (e^x + 3)^2$ 6) $y = xe^x$ 7) $y = \sin(e^x)$ 8) $y = e^{\sin x}$

9) $y = \ln(x + e^x)$ 10) $y = \frac{e^{4x}}{x}$ 11) $y = \frac{x}{e^{4x}}$ 12) $y = \sqrt[3]{e^x}$

Find dy/dx by implicit differentiation:

13) $xe^y + 8x - 3y = 0$

Find the second derivative of the function:

14) $y = e^x - e^{-x}$

15. Find relative extrema and inflection point(s) for the function $y = e^x - e^{-x}$.

16) Find the area of the largest rectangle that can be inscribed under the curve $y = 3 - e^x$ in the first quadrant.

Obviously, since the derivative of $y = e^x$ is e^x , it follows that the integral formula should be as simple.

$$\int e^x dx = e^x + C \text{ and if } u \text{ is a differentiable function of } x \text{ then } \int e^u du = e^u + C$$

Examples) Find the following:

17) $\int e^{5x} dx$

18) $\int 4e^{1-x} dx$

19) $\int 2xe^{x^2} dx$

20) $\int \frac{e^{1/x}}{2x^2} dx$

21) $\int \cos x \cdot e^{\sin x} dx$

22) $\int \frac{e^x}{4 - e^x} dx$

23) $\int \frac{e^x - e^{-x}}{e^x + e^{-x}} dx$

24) $\int \frac{e^{4x} + 2e^x + 1}{e^x} dx$

Find the area bounded by the curves and lines. Verify by calculator.

19) $y = e^{-x}, y = 0, x = 0, x = 1$

20) $y = \frac{e^x}{2 + e^x}, x = 1, y = 0$

21) $y = e^x \sin e^x, x = 0, y = 0$

22) Find the volume when the first quadrant region R bounded by $y = e^{x/2}$ and $x = 2$ is rotated about the x -axis.

Finally, occasionally, we have to take derivatives of exponential functions with bases other than e . Using the fact that $a^x = e^{(\ln a)x}$, we can take the derivative by saying that $\frac{d}{dx} a^x = e^{(\ln a)x} \cdot \ln a = a^x \cdot \ln a$. You need to know that:

$$\boxed{\frac{d}{dx} a^x = a^x \cdot \ln a \quad \text{and} \quad \frac{d}{dx} a^u = a^u \cdot \ln a \cdot \frac{du}{dx}}$$

Examples) Find the derivatives of:

23) $y = 5^x$

24) $y = 3^{x^2-2x}$

25) $y = x6^{-x}$

Derivatives and Integrals of Expressions with “e” - Homework

Find the derivatives of the following functions:

1. $y = e^{4x}$

2. $y = 16e^{-2x}$

3. $y = x^3e^x$

4. $y = \frac{e^x}{x^6}$

5. $y = e^x \tan x$

6. $y = 2\cos e^x$

7. $y = \frac{e^x}{\ln x}$

8. $y = \frac{\ln x}{e^x}$

9. $y = (e^x - 2x - 1)^3$

10. $y = \sqrt{e^{3x} - 4x}$

11. $y = -4e^{\sec x}$

12. $y = \frac{3}{e^x + e^{-x}}$

13. $y = \ln\left(\frac{1 - e^x}{1 + e^x}\right)$

14. $y = e^x(\sin x - \cos x)$

15. $y = \pi^x$

16. $y = 10^{x^2 - \sin x}$

Use implicit differentiation to find dy/dx

17. $xe^y - 2x - 3y = 0$

Find the second derivative of the following

18. $y = \sqrt{x} - e^x \ln x$

Find the extrema for the following functions:

19. $y = e^{\left(\frac{-x^2}{2}\right)}$

20. $y = 2xe^{-x}$

21. $y = x^2e^{-x}$

Find the following integrals

22. $\int e^{6x} dx$

23. $\int 4e^{-2x} dx$

24. $\int \sin x \cdot e^{\cos x} dx$

25. $\int \frac{e^{\tan x}}{\cos^2 x} dx$

26. $\int (e^x + e^{-x})^2 dx$

27. $\int e^x \sqrt{4 - e^x} dx$

28. $\int \frac{e^x + e^{-x}}{e^x - e^{-x}} dx$

29. $\int \frac{e^{2x} + 2e^{-x} + 1}{e^x} dx$

30. $\int \frac{e^{-x}}{4 + e^{-x}} dx$

31. $\int e^{-x} \tan(e^{-x}) dx$

32. $\int_1^9 \frac{e^{\sqrt{x}}}{2\sqrt{x}} dx$

33. $\int_1^{e^3} \frac{1}{x} dx$

Find the area of the region bounded by the graphs of the functions:

34. $y = e^{-x}, x = 0, y = 0, x = 4$

35. $y = xe^{-x^2/2}, x = 0, y = 0, x = \sqrt{2}$

36. Let R be the region bounded by $y = 6e^{-0.2x}$ and $y = \sqrt{x}$ and the lines $x = 1$ and $x = 4$. Find the volume when R is rotated about the x -axis.



37. Find the volume when the area between the graphs of the following functions is rotated about the x -axis:

$y = e^{x/2} + e^{-x/2}, y = 0, x = -2, x = 2$



Inverse Trig Functions - Classwork

The left hand graph below shows how the population of a certain city may grow as a function of time. If you are interested in finding the time at which the population reaches a certain value, it may be more convenient to reverse the variables and write time as a function of population. The relation you get by interchanging the two variables is called the **inverse** of the original function. The graph of the inverse is shown on the right graph below.

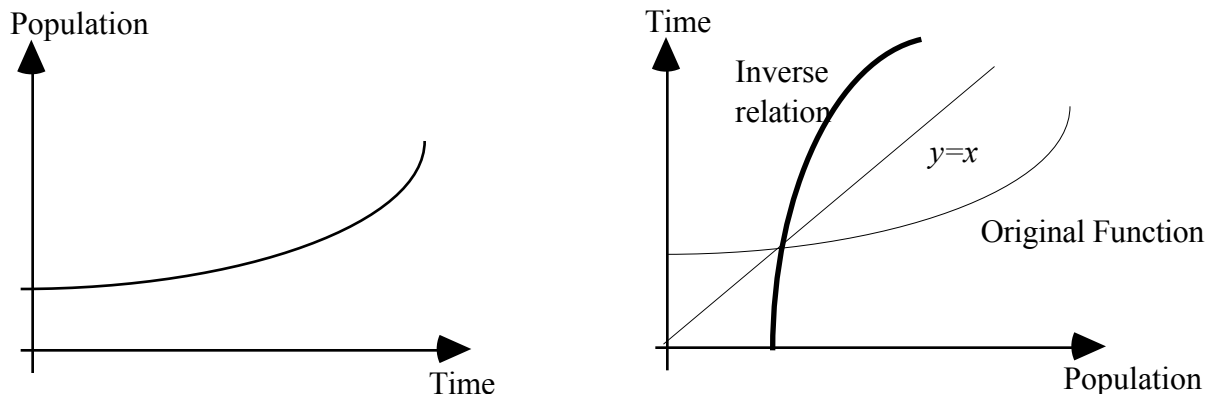

For a linear function such as $y = 2x + 6$, interchanging the variables gives $x = 2y + 6$ for the inverse relation. Solving for y in terms of x gives $y = .5x - 3$. The symbol f^{-1} , pronounced “ f inverse,” is used for the inverse function. If $f(x) = 2x + 6$, then $f^{-1}(x) = 0.5x - 3$.

If f^{-1} turns out to be a function (passes the vertical line test), the original function f is said to be **invertible**. Remember that the -1 exponent does *not* mean the reciprocal of $f(x)$. The inverse of a function undoes what the function did to x . That is $f^{-1}(f(x)) = x$. If $f(x) = x^2$, then $f^{-1}(x) = \sqrt{x}$. Note that if the same scales are used for the two axes, then the graphs of f and f^{-1} are mirror images with respect to the 45° line $y = x$.

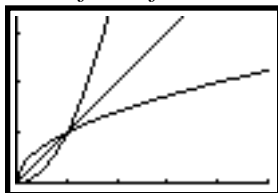

The inverses of the trigonometric functions follow from the definition. For instance, if the function is $y = \sin x$, the inverse function is given by $x = \sin y$. When we solve for y , we get $y = \sin^{-1} x$. The symbol **arcsin x** is sometimes used to help you distinguish $\sin^{-1} x$ from $1/\sin x$. Here are the graphs of $y = \sin x$ and $y = \sin^{-1} x$.

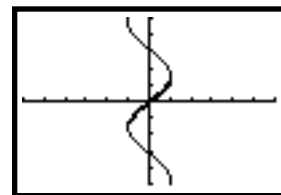
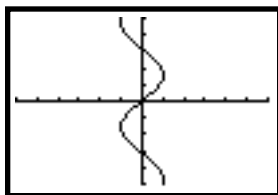
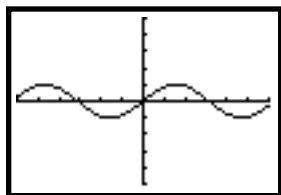

It is obvious that the inverse sine relation is not a function. There are many values of y for the same value of x . To create a function that is the inverse of $\sin x$ it is customary to restrict the range to $-\frac{\pi}{2} \leq y \leq \frac{\pi}{2}$. This includes only the branch of the graph nearest the origin. (3rd picture above).

Below are pictures of the inverse cosine function and inverse tangent function. Note that in order to ensure that these relations are functions, we have to restrict the range.

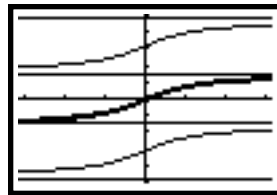
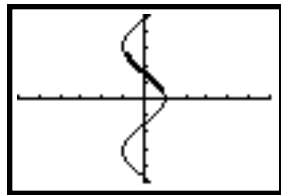

So, we have these definitions:

$$y = \sin^{-1} x \text{ if and only if } \sin y = x \text{ and } y \in \left[-\frac{\pi}{2}, \frac{\pi}{2}\right]$$

$$y = \cos^{-1} x \text{ if and only if } \cos y = x \text{ and } y \in [0, \pi]$$

$$y = \tan^{-1} x \text{ if and only if } \tan y = x \text{ and } y \in \left(-\frac{\pi}{2}, \frac{\pi}{2}\right)$$

You must know conversions of degrees to radians and special triangles.

2π radians = 360° or π radians = 180° . Some of the relationships that you should know are:

Degrees	30	45	60	90	120	135	150	180
Radians	$\frac{\pi}{6}$	$\frac{\pi}{4}$	$\frac{\pi}{3}$	$\frac{\pi}{2}$	$\frac{2\pi}{3}$	$\frac{3\pi}{4}$	$\frac{5\pi}{6}$	π

In a $30^\circ - 60^\circ - 90^\circ$ triangle, the sides are always in the proportion $1 - \sqrt{3} - 2$

In a $45^\circ - 45^\circ - 90^\circ$ triangle, the sides are always in the proportion $1 - 1 - \sqrt{2}$

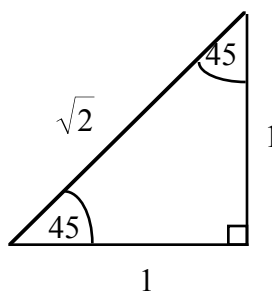
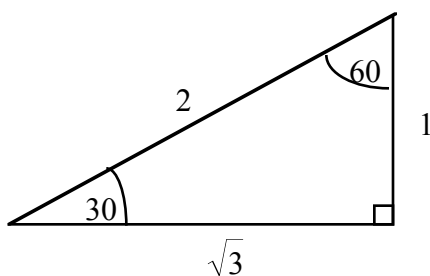

Example 1) Evaluate each of the following:

a) $\arcsin\left(-\frac{1}{2}\right)$

b. $\cos^{-1} 0$

c. $\tan^{-1} \sqrt{3}$

d. $\csc^{-1}(-\sqrt{2})$

Example 2) Evaluate the following. Make a picture to describe the situation.

a. $\sin\left(\arctan\frac{3}{4}\right)$

b. $\tan\left(\arccos\frac{\sqrt{2}}{2}\right)$

c. $\sec\left(\sin^{-1}\frac{1}{3}\right)$

d. $\cot\left(\cos^{-1}\frac{-2}{5}\right)$

Example 3) Evaluate the following. Make a picture to describe the situation.

a. $\cos(\sin^{-1} x)$

b. $\tan(\cos^{-1} x)$

c. $\sin(\cos^{-1} 2x)$

d. $\sin(\tan^{-1} 3x)$

So now we can take derivatives of inverse trig functions. Find $\frac{d}{dx}(\sin^{-1} x)$

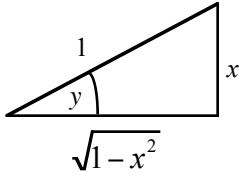
<p>$y = \sin^{-1} x \iff \sin y = x$</p> <p>Draw a picture</p> <p>the angle is y, opposite = x, hypotenuse = 1</p> <p>Remaining side is $\sqrt{1-x^2}$</p>	
--	--

Since $\sin y = x$, take the derivative of each side

$$\cos y \frac{dy}{dx} = 1 \quad \text{or} \quad \frac{dy}{dx} = \frac{1}{\cos y} \quad \text{or} \quad \frac{dy}{dx} = \frac{1}{\sqrt{1-x^2}}$$

Example 4) Take the derivative of

a. $y = \cos^{-1} x$

b. $y = \tan^{-1} x$

The derivatives of the three inverse trig functions are as follows:

$$\frac{d}{dx}(\sin^{-1} u) = \frac{1}{\sqrt{1-u^2}} \frac{du}{dx}$$

$$\frac{d}{dx}(\cos^{-1} u) = \frac{-1}{\sqrt{1-u^2}} \frac{du}{dx}$$

$$\frac{d}{dx}(\tan^{-1} u) = \frac{1}{1+u^2} \frac{du}{dx}$$

Example 5) Find the derivatives of

a. $y = \sin^{-1} 4x$

b. $y = \tan^{-1} x^3$

c. $y = \left(\cos^{-1} \frac{x}{2}\right)^3$

d. $y = x \sin^{-1} x + \sqrt{1-x^2}$

Example 6) An officer in a patrol car sitting 100 feet from the highway observes a truck approaching. At a particular instant t seconds, the truck is x feet down the road. The line of sight to the truck makes an angle of θ radians to a perpendicular line to the road.

a. Express θ as an inverse trig function.

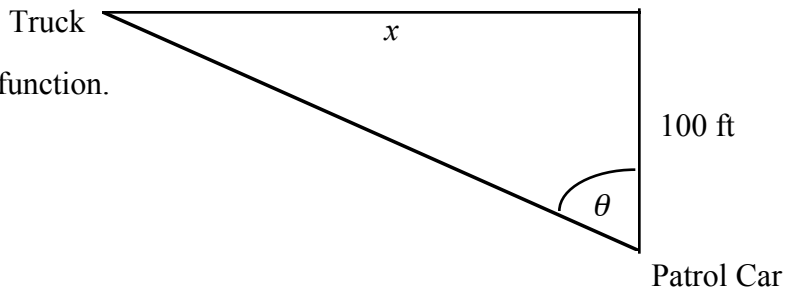

b. Find $\frac{d\theta}{dt}$

c. When the truck is at $x = 500$ ft, the angle is observed to be changing at a rate

$$\frac{d\theta}{dt} = -2 \text{ degrees/sec. How fast is the car going in ft/sec and mph?}$$

Inverse Trig Functions - Homework

1. Evaluate each of the following:

a. $\arccos \frac{1}{2}$

b. $\cot^{-1} \sqrt{3}$

c. $\sin^{-1} \frac{-\sqrt{3}}{2}$

d. $\sec^{-1} -\frac{2\sqrt{3}}{3}$

2. Evaluate the following. Make a picture to describe the situation.

a. $\cos\left(\arcsin \frac{-3}{5}\right)$

b. $\sin\left(\arctan \frac{12}{5}\right)$

c. $\csc(\cot^{-1} 4)$

d. $\tan(\csc^{-1} \sqrt{3})$

3. Evaluate the following. Make a picture to describe the situation.

a. $\cos(\tan^{-1} x)$

b. $\sec(\sin^{-1} x)$

c. $\tan(\sin^{-1} 4x)$

d. $\cos(\tan^{-1}(x+3))$

4. Find the derivatives of

a. $y = \cos^{-1}(3x)$

b. $y = \sin^{-1}(x^2 - 1)$

c. $y = (\tan^{-1} 2x)^5$

d. $y = \sqrt{(\cos^{-1} 10x)}$

e. $y = \arctan \sqrt{x}$

f. $y = \sin(\cos^{-1} t)$

5. Find any relative extrema of $y = \arcsin x - x$

6. The base of a 20 foot tall exit sign is 30 feet above the driver's eye level. When cars are far away, the sign is hard to read because of the distance. When they are close, the sign is hard to read because the driver has to look up at a steep angle. The sign is easiest to read when the distance x is such that the angle θ at the driver's eye is as large as possible.

a) Write θ as the difference of 2 inverse tangents.

b) Write an equation for $\frac{d\theta}{dx}$

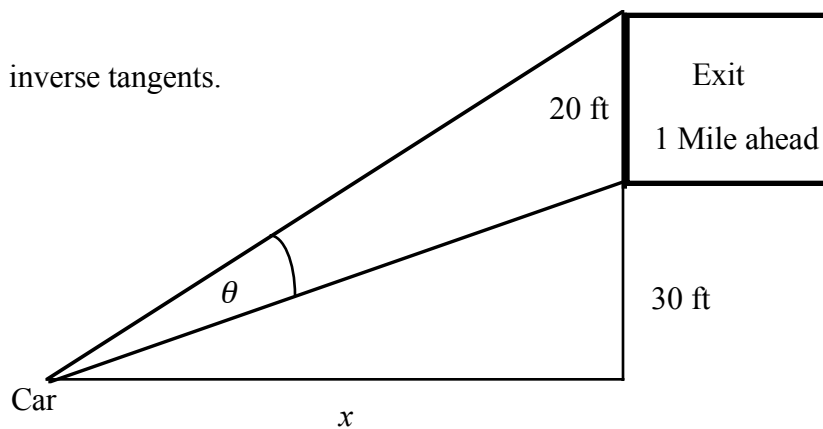

c) The sign is easiest to read at the value of x where θ stops increasing and starts decreasing. This happens when $\frac{d\theta}{dx} = 0$. Find x and confirm using the calculator.

Inverse Trig Functions Integration - Classwork

If u is a differentiable function of x , and $a > 0$ then

$$\int \frac{du}{\sqrt{a^2 - u^2}} = \sin^{-1} \frac{u}{a} + C$$

$$\int \frac{du}{a^2 + u^2} = \frac{1}{a} \tan^{-1} \frac{u}{a} + C$$

1. $\int \frac{dx}{\sqrt{1-x^2}}$

2. $\int \frac{dx}{\sqrt{4-x^2}}$

3. $\int \frac{dx}{1+x^2}$

4. $\int \frac{dx}{\sqrt{5-2x^2}}$

5. $\int \frac{x dx}{\sqrt{5-2x^2}}$

6. $\int \frac{e^x}{9+e^x} dx$

7. $\int \frac{x+2}{\sqrt{4-x^2}} dx$

8. $\int \frac{x+2}{x^2+4} dx$

9. $\int \frac{x^3}{x^2+1} dx$

Inverse Trig Functions Integration - Homework

1. $\int \frac{dx}{1+4x^2}$

2. $\int \frac{dx}{\sqrt{4-x^2}}$

3. $\int \frac{dx}{4+(x-1)^2}$

4. $\int \frac{t}{\sqrt{1-t^4}} dt$

5. $\int \frac{x}{x^4+16} dx$

6. $\int \frac{\sin^{-1} x}{\sqrt{1-x^2}} dx$

7. $\int \frac{\sin x}{1+\cos^2 x} dx$

8. $\int \frac{e^{2x}}{9+e^{4x}} dx$

9. $\int_0^{\sqrt{3}/2} \frac{1}{1+4x^2} dx$

10. Find the area of the region bounded by the curves
 $y = \frac{1}{\sqrt{4-x^2}}$, $y = 0$, $x = 0$, $x = 1$

Derivatives of Inverse Functions - Classwork

General Problem: Find the derivative of the inverse function of $f(x)$ at $x = k$.

Method 1: Simply finding the inverse function. This works when it is easy to generate the inverse function.

- a) Find the inverse function by interchanging x and y and solving for y
- b) Take the derivative of this new y . That will be the derivative of the inverse function.
- c) Plug in your given k value

Method 2: Not finding the inverse function because it is too difficult

- a) Find the inverse function by interchanging x and y
- b) find $\frac{dy}{dx}$ implicitly
- c) Solve for $\frac{dy}{dx}$. It will be in terms of y .
- d) Replace the value of k for x in your inverse function from step a) above and solve for y
- e) Plug that value of y into $\frac{dy}{dx}$

Example: If $f(x) = x^2, x \geq 0$, find the derivative of $f^{-1}(x)$ at $x = 4$.

METHOD 1

a) $y = x^2$, so the inverse is $x = y^2$

therefore $y = \sqrt{x}$ (first quadrant)

b) $y' = \frac{1}{2\sqrt{x}}$

c) $y'(4) = \frac{1}{2\sqrt{4}} = \frac{1}{4}$

METHOD 2

a) $y = x^2$, so the inverse is $x = y^2$

b) $1 = 2y \frac{dy}{dx}$

c) $\frac{dy}{dx} = \frac{1}{2y}$

d) $4 = y^2 \Rightarrow y = 2$ (quad I)

e) $\frac{dy}{dx} = \frac{1}{2y} = \frac{1}{2(2)} = \frac{1}{4}$

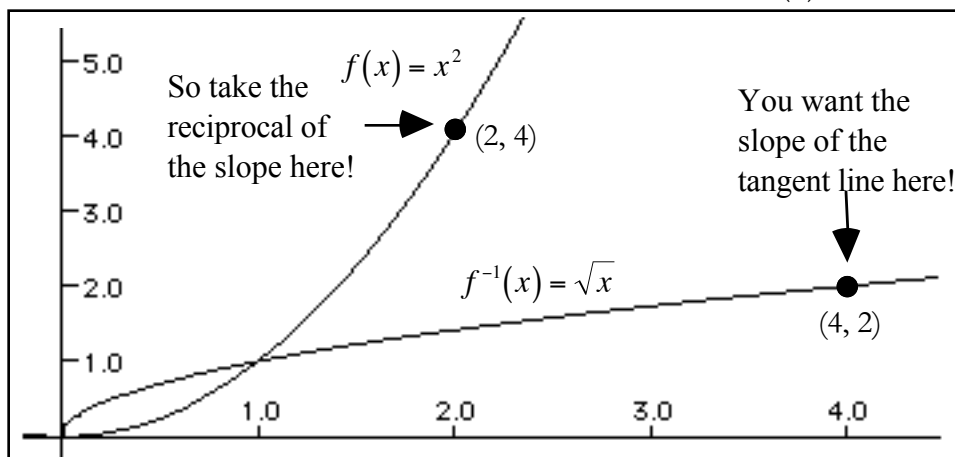

Note: It was necessary to restrict the domain of $f(x)$ to $x \geq 0$ so that its inverse is a function: i.e. that $f(x)$ is one-to-one (passes the horizontal line test).

Example: Find the derivative of the inverse function of $f(x) = x^3 - 4x^2 + 7x - 1$ at $x = 1$.

Method 1 will be too difficult. $y = x^3 - 4x^2 + 7x - 1$ so the inverse is $x = y^3 - 4y^2 + 7y - 1$

a) $1 = (3y^2 - 8y + 7) \frac{dy}{dx} \Rightarrow \frac{dy}{dx} = \frac{1}{3y^2 - 8y + 7}$

b) Set $y^3 - 4y^2 + 7y - 1 = 1$. Graphically, you get $y = 0.349$.

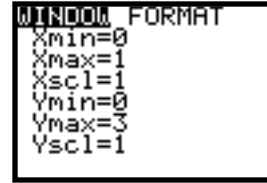
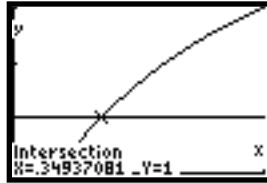

c) $\frac{dy}{dx} = \frac{1}{3(.349)^2 - 8(.349) + 7} = .219$

Example: Find the derivative of the inverse function of $f(x) = e^x + \ln x$ at $x = 3$.

Method 1 will be too difficult. $y = e^x + \ln x$ so the inverse is $x = e^y + \ln y$

a) $1 = \left(e^y + \frac{1}{y} \right) \frac{dy}{dx} \Rightarrow \frac{dy}{dx} = \frac{1}{e^y + \frac{1}{y}}$ or $\frac{dy}{dx} = \frac{y}{ye^y + 1}$

b) Set $e^y + \ln y = 3$. Graphically, you get $y = 1.074$.

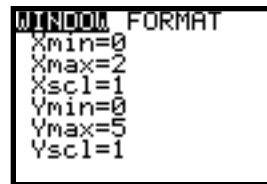
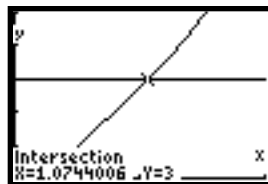

c) $\frac{dy}{dx} = \frac{1}{e^{1.0744} + \frac{1}{1.0744}} = .259$

Note: After you graphically intersect, you can easily get the answer by $\frac{1}{nDeriv(Y1,X,X)}$

Example: Find the derivative of the inverse function of $y = e^{x^2}, x > 0$.

Inverse Function: $x = e^{y^2}$

$\ln x = y^2$

Solution: $y = \sqrt{\ln x} = (\ln x)^{1/2}$

$\frac{dy}{dx} = \frac{1}{2}(\ln x)^{-1/2} \frac{1}{x} = \frac{1}{2x(\ln x)^{1/2}}$

Sample Problems: Find the derivative of the inverse function of (use method 2 only if method 1 won't work)

a) $y = x^3 + 1$ at $x = 9$

b) $y = x^3 + 5x - 1$ at $x = 5$

c) $y = x + \sin x$ at $x = \pi$

Derivatives of Inverse Functions - Homework

For the problems below, find the derivative of f^{-1} for the function f at the specified value of x . No calculators.

1. $f(x) = x^3 + 2x - 1$ at $x = 2$

2. $f(x) = 2x^5 + x^3 + 1$ at $x = 4$

3. $f(x) = \sin x$ $-\frac{\pi}{2} \leq x \leq \frac{\pi}{2}$ at $x = \frac{1}{2}, 2)$

4. $f(x) = \cos 2x$ $-\frac{\pi}{2} \leq x \leq \frac{\pi}{2}$ at $x = 1$

5. $f(x) = x^3 - \frac{4}{x}$ $x > 0$ at $x = 6$

6. $f(x) = \sqrt{x-4}$ at $x = 2$

For the problems below, find the derivative of f^{-1} for the function f at the specified value of x . Use calculators.

7. $f(x) = x^3 - 2x^2 + 5x - 1$ at $x = 2$

8. $f(x) = \sqrt[3]{3x-5}$ at $x = -3$

9. $f(x) = \frac{x}{2} + \sin^2 x$ at $x = 3$

10. $f(x) = xe^{\cos x}$ at $x = 3$

Differential Equations by Separation of Variables - Classwork

A differential equation will be in the form of $\frac{dy}{dx} = f(x) \cdot g(y)$. In order to solve it, you must put it in the form of $g(y) \cdot dy = f(x) \cdot dx$ allowing you to integrate. Your goal is to get an equation in the form of $y = h(x)$

1) $\frac{dy}{dx} = \frac{2x}{y}$

2) $\frac{dy}{dx} = y^2$

3) $\frac{dy}{dx} = \frac{x + \sin(x)}{3y^2}$

4) $\frac{dy}{dx} = 4y$

5) $\frac{dy}{dx} = ky$

6) $\frac{dy}{dx} = xy$

7) $\frac{du}{dt} = e^{u+2t}$

8) $\frac{dx}{dt} = 1 + t - x - tx$

Find the solution of the differential equation that satisfies the given condition.

9. $xe^{-t} \frac{dx}{dt} = 1, x(0) = 1$

10. $\frac{dy}{dx} = \frac{1+x}{xy}, y(1) = -4$

11. $\frac{dy}{dx} = y^2 + 1, y(1) = 0$

12. $x + 2y\sqrt{x^2 + 1} \frac{dy}{dx} = 0, y(0) = 1$

Differential Equations by Separation of Variables - Homework

1. $\frac{dy}{dx} = \frac{x}{y}$

2. $\frac{dy}{dx} = \frac{x^2 + 2}{3y^2}$

3. $x \frac{dy}{dx} = y$

4. $(2 + x) \frac{dy}{dx} = 3y$

5. $yy' = \sin x$

6. $(1 + 4x^2)y' = 1$

Find the solution of the differential equation that satisfies the given condition.

7. $\sqrt{x} + \sqrt{y} \frac{dy}{dx} = 0$, $y(1) = 4$

8. $y \frac{dy}{dx} = e^x$, $y(0) = 4$

9. $xy \frac{dy}{dx} - \ln x = 0$, $y(1) = 0$

10. $y(x+1) + \frac{dy}{dx} = 0$, $y(-2) = 1$

11. $(1 + x^2) \frac{dy}{dx} - (1 + y^2) = 0$, $y(0) = \sqrt{3}$

12. $dT + k(T - 70)dt = 0$, $T(0) = 140$

Slope Fields - Classwork

In this section, we can solve differential equations by obtaining a *slope field* (sometimes called a *direction field*) that approximates the general solution. The slope field of a first-order differential equation says that the differential equation can be interpreted as a statement about the slopes of its solution curves. You are given dy/dx .

1) $\frac{dy}{dx} = y$. Fill in the chart for $\frac{dy}{dx}$

(x, y)	-3	-2	-1	0	1	2	3
3							
2							
1							
0							
-1							
-2							
-3							

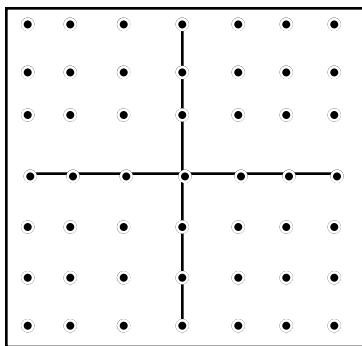

Find the solution going through

- a) (1, 1) b) (-2, 0)

2) $\frac{dy}{dx} = \frac{1}{x}$. Fill in the chart for $\frac{dy}{dx}$

(x, y)	-3	-2	-1	0	1	2	3
3							
2							
1							
0							
-1							
-2							
-3							

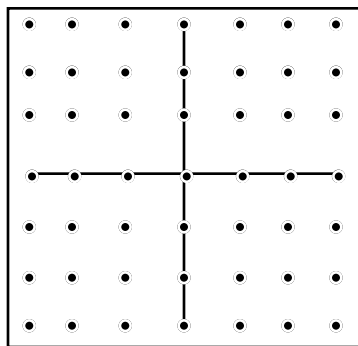

Find the solution going through

- a) (1, 1) b) (-2, -1)

3) $\frac{dy}{dx} = \frac{-x}{y}$. Fill in the chart for $\frac{dy}{dx}$

(x, y)	-3	-2	-1	0	1	2	3
3							
2							
1							
0							
-1							
-2							
-3							

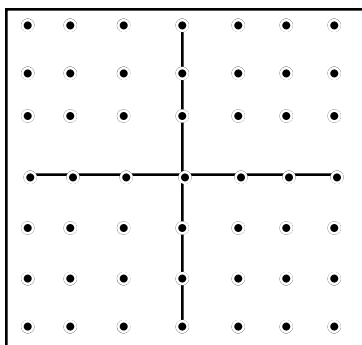

Find the solution going through

- a) (1, 1) b) (-2, 0)

4) $\frac{dy}{dx} = x + y$. Fill in the chart for $\frac{dy}{dx}$

(x, y)	-3	-2	-1	0	1	2	3
3							
2							
1							
0							
-1							
-2							
-3							

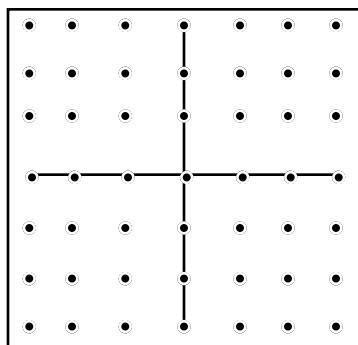

Find the solution going through

- a) (1, 1) b) (-2, -1)

Slope Fields - Homework

1. $\frac{dy}{dx} = \frac{x}{y}$ Fill in the chart for $\frac{dy}{dx}$.

(x, y)	-3	-2	-1	0	1	2	3
3							
2							
1							
0							
-1							
-2							
-3							

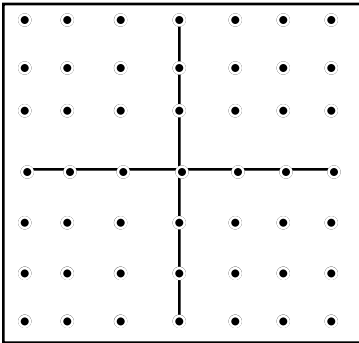

Find the solution going through
 a) (0, 1) b) (1, 0) c) (0, 3)

2. $\frac{dy}{dx} = x - y$ Fill in the chart for $\frac{dy}{dx}$.

(x, y)	-3	-2	-1	0	1	2	3
3							
2							
1							
0							
-1							
-2							
-3							

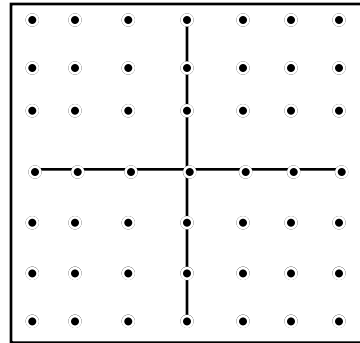

Find the solution going through
 a) (0, 0) b) (0, -1) c) (1, -2)

3. $\frac{dy}{dx} = \sin x$ Fill in the chart for $\frac{dy}{dx}$.

(x, y)	-3	-2	-1	0	1	2	3
3							
2							
1							
0							
-1							
-2							
-3							

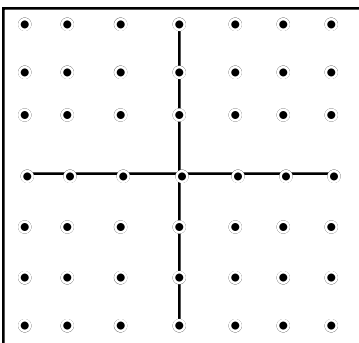

Find the solution going through
 a) (0, 0) b) (1, 0)

4. $\frac{dy}{dx} = x(1+y)(2-y)$ Fill in the chart for $\frac{dy}{dx}$.

(x, y)	-3	-2	-1	0	1	2	3
3							
2							
1							
0							
-1							
-2							
-3							

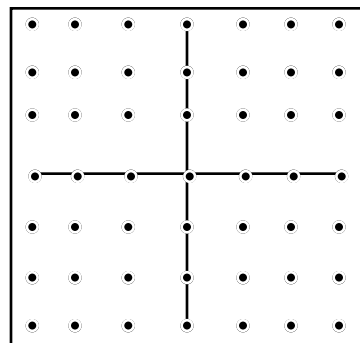

Find the solution going through
 a) (0, 0) b) (0, 1)

Exponential Growth - Classwork

Consider the statement “The rate of change of some quantity y is directly proportional to y ”

This is like saying that the more money you have (y), the faster it will grow $\left(\frac{dy}{dt}\right)$, or the more you scratch an insect bite, the worse it will get, or the more addicted someone is to a substance, the more the addiction will grow.

“The rate of change of some quantity y is directly proportional to y ” can be translated thusly:

quantity = y **rate of change of y** = $\frac{dy}{dt}$ **directly proportional** = multiplied by some constant k

So this statement can be translated: $\frac{dy}{dt} = ky$ k is sometimes called the growth (or decay) constant

This is a differential equation and can be solved:

$\frac{dy}{y} = k dt$	Separate the variables
$\int \frac{dy}{y} = \int k dt$	Integrate both sides
$\ln y = k t + C$	Perform the integration. Put the $+C$ on the right side
$ y = e^{kt+C}$	Write this exponentially
$y = e^{kt+C}$	Drop the absolute value as e raised to any power > 0
$y = e^{kt} \cdot e^C$	Split the right side into 2 factors
$y = C e^{kt}$	e^C is simply a constant
$y = y_0 e^{kt}$	When $t = 0$, $y = C$. We call the constant y_0

So, the statement: the rate of change of some quantity y is directly proportional to y is translated:

$$\frac{dy}{dt} = ky \text{ which can in turn be translated into } y = C e^{kt} \text{ or } y = y_0 e^{kt}$$

KNOW THIS BACKWARD AND FORWARD

Example 1: *Punctured Tire Problem:* You run over a nail. As the air leaks out of your tire, the rate of change of air pressure inside the tire is directly proportional to that pressure.

- a. Write a differential equation that states that fact if the pressure is 35 lbs/psi and decreasing at the rate of .28 lbs/psi/min at the time the nail is struck.

b. Solve that differential equation

c. What will the pressure be at 10 minutes after the tire was punctured.

d. The car is safe to drive as long as the pressure is 12 lbs/psi or greater. For how long after the puncture will the car be safe to drive?

Example 2: Bacteria in a lab culture grows in such a way that the instantaneous rate of change of bacteria is directly proportional to the number of bacteria present.

a) Write a differential equation that expresses the relationship.

b) Solve the differential equation for the number of bacteria as a function of time.

c) Suppose that initially there are 5 million bacteria and three hours later, that number has grown to 7 million. Write the particular equation that expresses the number of millions of bacteria as a function of hours.



d) Sketch the graph of time vs. bacteria over 10 hours

e) What will the bacteria population be one full day after the first measurement?

f) When will the population reach 1 billion?
Show your work

Exponential Growth - Homework

1. Major purchases like cars depreciate in value. That is, as time goes on, their value goes down. So the change in a car's price is directly proportional to its current value.

a) Write a differential equation that expresses this relationship, and then solve the DEQ for the value of the car.

b) Suppose you own a car whose trade-in value is presently \$4200. Three months ago, its trade-in value was \$4700. Find the particular equation that expressed the trade-in value since the car was worth \$4700.

c) Sketch the graph of this equation over 2 years.

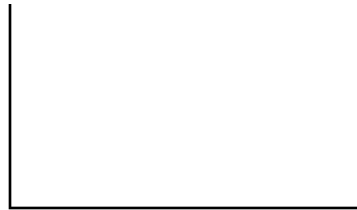

d) What will be the trade-in value of the car one year after the car was worth \$4700?

e) You plan to get rid of the car when its trade-in value drops to \$1200. When will this be?

f) At the time your car was worth \$4700, it was 31 months old. What was its trade-in value when it was new?

g) The purchase price of the car when it was new was \$16,000. How do you explain the difference between this number and f)?

2. Carbon 14 is an isotope of carbon that is formed when radiation from the sun strikes ordinary carbon dioxide in the atmosphere. Thus plants such as trees, which get their carbon dioxide from the atmosphere, contains small parts of carbon 14. The rate of carbon 14 decay is directly proportional to the amount present.

a) Write a differential equation that expresses this relationship where P is the percentage of carbon 14 that remains in a tree that grew t years ago.

b) Solve the differential equation for P in terms of t . Use the fact that the half-life of carbon 14 is 5750 years to solve the particular equation for the constant P_0 . (If $P = 100$ when $t = 0$, then $P = 50$ when $t = 5750$).

- c) The oldest living trees in the world are the bristlecone pines in the White Mountains of California. 4000 growth rings have been counted in the trunk of one of these trees, meaning that the innermost ring grew 4000 years ago. What percentage of the original carbon 14 would you expect to find in this innermost ring?
- d) A piece of wood claimed to have come from Noah's Ark is found to have 48.37% of the carbon 14 remaining. It has been suggested that the Great Flood occurred in 4004 BC. Is the wood old enough to have come from Noah's Ark? Show why or why not.
3. The rate of change of atmospheric pressure P with respect to altitude h is proportional to P , provided that the temperature is constant. At 15°C , the pressure is 101.3 at sea level and 87.1 at height $h = 1000\text{m}$.
- a) Write a differential equation that expresses this relationship where P is the pressure and h is the altitude. Then solve the particular DEQ given the information above.
- b) What is the pressure at the top of Mt. McKinley at an altitude of 6187 meters?
- c) At what altitude is the pressure equal to 50?
4. You accidentally inhale some poisonous fumes. Twenty hours later, you still feel woozy so you go to a doctor. From blood samples, he measures a poison concentration of .00372 mg/ml and tells you to come back in 8 hours. On the second visit, he measures a concentration of .00219 mg/ml.
- Let t be the number of hours since your first doctor visit and C be the concentration of poison in your blood. The rate of change of C is directly proportional to the current value of C .
- a) Write a DEQ that relates these two variables.
- b) Solve the differential equation subject to initial conditions specified. Express C as a function of t .
- c) The doctor says that you might have serious body damage if the poison concentration has ever been as high as 0.015 mg/ml. Based on your equation, was the concentration ever that high? Justify your answer.

5. The rate in which whooping cough spreads is proportional to the amount of whooping cough cases there presently is. In the course of any year, the number of whooping cough cases is reduced by 20%.
- Write a DEQ that states the situation above and then solve the DEQ.
 - If there are 10,000 cases today, how many years will it take for the number of cases to reduce to 100?
 - If the cases can be reduced by 25% instead of 20%, how long will it take to reduce to 100 cases?
 - Using part c), how long will it take to eradicate the disease (reduce # of cases to less than 1)?
6. John Napier, who invented natural logarithms, was the first person to answer the question: If money compounds at a rate proportional to the amount you now have, and you invest money at 5% interest,
- Write and solve the DEQ which states the above.
 - how long will it take \$100 to grow to \$1,000?
 - how long will it take any amount of money to triple?
 - if you invest \$1,000, when will you be a millionaire?
7. The processing of raw sugar has a step called “inversion” that changes the sugar’s molecular structure. Once the process has begun, the rate of change of the amount of sugar is proportional to the amount of raw sugar remaining. If 1,000 kg of raw sugar reduces to 800 kg of raw sugar during the first 10 hours, how much sugar will remain after another 12 hours?

Exponential Growth Continuation - Classwork

Remember that you can always translate $\frac{dy}{dt} = ky$ into $y = Ce^{kt}$ if and only if the original statement is:

The rate of change of some quantity y is directly proportional to y . Suppose it isn't? For example:

- a) the rate of change of y is proportional to $4y$. b) the rate of change of y is proportional to $4 - y$.

- c) the rate of change of y is inversely proportional to y . d) the rate of change of y is proportional to \sqrt{y} .

Example. Suppose you fill a tall tin can with water and then punch out a hole near the bottom. The water leaks out quickly at first, then more slowly as the depth of the water decreases. In physics, it can be proved that the rate at which the water's height h changes (i.e. leaks out) is directly proportional to the square root of its height.

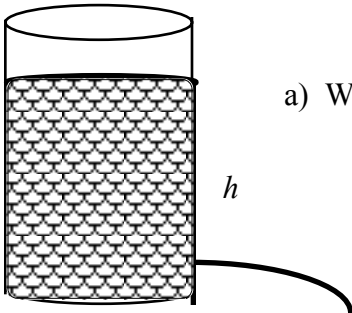

- a) Write a differential equation which states this relationship.

b) Suppose that at time $t = 0$ min, the height is 12 cm and $dh/dt = -3$ cm/sec. Find the value of k which satisfies this relationship.

c) Solve this differential equation to find h as a function of t . Use the given information to find the particular solution. What kind of function is this?

d) Solve algebraically for the time when the can becomes empty.

Exponential Growth Continuation - Homework

1. A curve passes through the point $(0, 5)$ and has the property that the slope of the curve at every point P is twice the y -coordinate of P . What is the equation of the curve?

2. Newton's Law of Cooling states that the rate of cooling of an object is proportional to the temperature difference between the object and the outside air. Suppose that a roast turkey is taken from the oven when its temperature has reached 185° and is placed on a table where the temperature is 75° . If R is the temperature of the turkey after t minutes, then Newton's Law of Cooling implies that:

$$\frac{dR}{dt} = k(R - 75)$$

a) Solve the differential equation for R . Then use the given information to find the particular solution.

b) If the temperature of the turkey is 150° after half an hour, what is the temperature after 45 minutes?

c) When will the turkey have cooled to 100° ?

3. The change of rate of coyotes N in a population is directly proportional to $650 - N$. (where t is the time in years. When $t = 0$, the population is 300 and when $t = 2$, the population has increased to 500.

a) Write and solve a differential equation that describes this situation.

b. Find the coyote population in 3 years

c. Find $\lim_{t \rightarrow \infty} N(t)$

4. Let $P(t)$ represent the number of students in a school who buy their lunch after t weeks. Suppose P is increasing at a rate proportionally to $600 - P$ where the constant of proportionality is k .
- Write the DEQ which states that fact.
 - If 300 students buy their lunch initially and 400 buy their lunches after 10 weeks, solve the DEQ.
 - How many students will buy their lunch after 20 weeks?
 - If school went on endlessly using this pattern, what is the limit to the number of students buying lunch?
5. You win a well-known national sweepstakes. Your award is \$100 a day for the rest of your life! You put the money in a bank where it earns interest at a rate directly proportional to the amount M which is in the account. So, $\frac{dM}{dt} = 100 + kM$ where k is the growth constant.
- Solve the DEQ in general given the fact that at $t = 0$ days, there is no money in the account.
 - Suppose you invest the money at 5% APR So $k = \frac{.05}{365}$. Solve the DEQ completely.
 - How much will you have at the end of a year?
 - Assuming you live for 75 more years, how much will you take to the grave with you if you never spend it?
 - How long will it take you to become a millionaire? How about a billionaire? Calculators allowed.

Finding “Impossible” Integrals - Classwork

Example: Let $F(x)$ be an antiderivative of $\frac{x}{x^3+1}$. If $F(0) = 2$, find $F(3)$.

Solution: We need to take the integral of $\frac{x}{x^3+1}$. But can we? u -substitution does not work. We cannot split the function. There seems to be no possibility for inverse-trig. So how can we do the problem?

We are not being asked to find the indefinite integral of the expression. We just need to find the value of the integral function of this expression at 3.

$$\text{So, if } F(x) = \int \frac{x}{x^3+1} dx, \text{ then } F(3) - F(0) = \int_0^3 \frac{x}{x^3+1} dx \text{ and thus } F(3) = 2 + \int_0^3 \frac{x}{x^3+1} dx.$$

Using the calculator: $F(3) = 2 + .879 = 2.879$.

2) Let $F(x)$ be an antiderivative of $\sqrt{4x^2+5}$. If $F(1) = 3$, find $F(5)$.

3. Let $F(x)$ be an antiderivative of e^{x^2} . If $F(-1) = 2$, find $F(-2)$.

Finding “Impossible” Integrals - Homework

1. Let $F(x)$ be an antiderivative of $\frac{5x-2}{8x^4+2}$. If $F(1) = 3$, find $F(6)$.

2. Let $F(x)$ be an antiderivative of $\sqrt[3]{5x^2-4}$. If $F(2) = 7$, find $F(5)$.

3. Let $F(x)$ be an antiderivative of $\sin^3 x$. If $F(-1) = 4$, find $F(4)$

4. Let $F(x)$ be an antiderivative of $\ln(x^2+4x+12)$. If $F(10) = -2$, find $F(-1)$

L'Hopital's Rule for Indeterminate Forms - Classwork

There are 7 expressions which are considered to have an **indeterminate form**. That is -- we can not assign a definite value to the expression without further investigation. Perhaps there is a limit. Perhaps there is no limit (i.e. the limit is $\pm \infty$). These expressions are (when plugged in)

$$\frac{0}{0}, \frac{\infty}{\infty}, 0 \cdot \infty, 1^\infty, \infty - \infty, \infty^0$$

We now have a way of evaluating any expression of the form $\frac{f(x)}{g(x)} = \frac{0}{0} = \frac{\infty}{\infty}$

L'Hopital's Rule states that if $\lim_{x \rightarrow a} \frac{f(x)}{g(x)} = \frac{0}{0}$ or $\frac{\infty}{\infty}$ then $\lim_{x \rightarrow a} \frac{f(x)}{g(x)} = \lim_{x \rightarrow a} \frac{f'(x)}{g'(x)}$

Type 1 - Simple L'Hopital's Rule for Polynomials and Powers

1. $\lim_{x \rightarrow 2} \left(\frac{3x^2 - 7x + 2}{x - 2} \right)$

2. $\lim_{x \rightarrow 3} \frac{x + 3}{\sqrt{x^2 - 5} - 2}$

Note that L'Hopital's Rule will not work unless this expression is an indeterminate form. $\lim_{x \rightarrow 2} \left(\frac{2x + 3}{x} \right) = \frac{7}{2}$, and not 2.

Type 2 - Repeated Use of L'Hopital's Rule for Polynomials

3. $\lim_{x \rightarrow -2} \frac{x^3 + x^2 - 8x - 12}{x^3 + 8x^2 + 20x + 16}$

4. $\lim_{x \rightarrow 1} \left(\frac{2x^4 - 7x^3 + 9x^2 - 5x + 1}{2x^4 - 5x^3 + 3x^2 + x - 1} \right)$

Type 3 - L'Hopital's Rule for Transcendental Functions and Trig

5. $\lim_{x \rightarrow 1} \left(\frac{\ln x - x + 1}{e^x - e} \right)$

6. $\lim_{x \rightarrow 0} \left(\frac{x^2 \sin x + \cos x - 1}{x} \right)$

Type 4 - L'Hopital's Rule for $\pm \frac{\infty}{\infty}$

1. $\lim_{x \rightarrow \infty} \frac{2x^3 - 4x^2 - 5x - 2}{3x^3 - 12}$

2. $\lim_{x \rightarrow \infty} \frac{4x^2 - 5x + 2}{e^{5x} + \ln x}$

L'Hopital's Rule for Indeterminate Forms - Homework

Basic Problems - calculate your answers and check on your calculators

1. $\lim_{x \rightarrow -1} \frac{2x^2 - x - 3}{x + 1}$

2. $\lim_{x \rightarrow 3} \frac{x^2 - x - 6}{x - 3}$

3. $\lim_{x \rightarrow 3} \frac{x^2 - x - 3}{x - 2}$

4. $\lim_{x \rightarrow 1} \frac{x - 1}{\sqrt{x^2 + 3} - 2}$

5. $\lim_{x \rightarrow 0} \frac{x}{1 - e^x}$

6. $\lim_{x \rightarrow 1} \frac{x^3 - 3x + 2}{x^3 - x^2 - x + 1}$

7. $\lim_{x \rightarrow 1} \frac{1 - x + \ln x}{x^3 - 3x + 2}$

8. $\lim_{x \rightarrow 0} \frac{x \cos x - \sin x}{x}$

9. $\lim_{x \rightarrow \infty} \frac{x^2 - 1}{4x^2 + x}$

10. $\lim_{x \rightarrow \infty} \frac{2x^2 + 4x - 7}{x^3 + 3x^2 - 5}$

11. $\lim_{x \rightarrow \infty} \frac{x^3}{e^x}$

12. $\lim_{x \rightarrow \infty} \frac{\sqrt{x^2 - 1}}{2x + 1}$